

ITEM NO.	PART NUMBER	QTY
1	BZSPH200ASFPSWB	1
2	BZV200WNYRB5	1
3	AXLE KIT	
	WP20X40X2	2
	TUBEM20X60	1
	HEXBOLTM12X90Z8.8	1
	NYLOCM12Z14MM	1

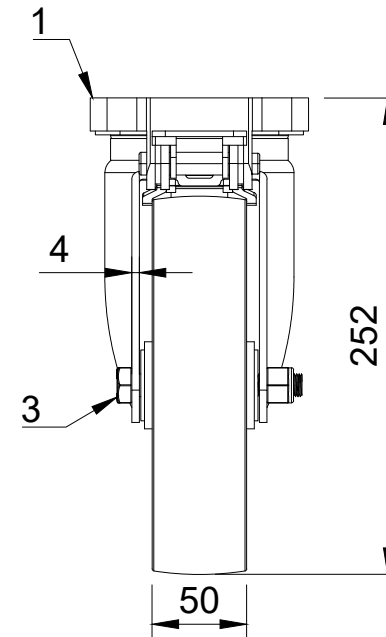

UNLESS OTHERWISE SPECIFIED DIMENSIONS ARE IN MILLIMETRES

Unspecified Tolerances  
Machining ± 0.25mm  
Fabrication ± 1mm

DRAWING DISCLAIMER

COPYRIGHT OF THIS DRAWING IS RESERVED BY BIL GROUP LTD. IT IS NOT REPRODUCED, COPIED, OR DISCLOSED TO A THIRD PARTY EITHER WHOLLY OR IN PART WITHOUT THE CONSENT IN WRITING OF BIL GROUP LTD

	NAME	DATE
DRAWN BY	Matt	14/11/23
APPROVED BY	Kevin	14/11/23
SCALE	1:4	
WEIGHT		

**BILGroup**

BIL Group Ltd  
Porte Marsh Road  
Calne, Wiltshire, SN11 9BW  
United Kingdom  
Tel +44 (0)1249 822 222  
www.bilgroup.co.uk

DWG NO. **BZSPH200NYBFPSWB** REV **1**

**BZSPH200NYBFPSWB** SHEET 1 OF 1