

ITEM NO.	PART NUMBER	QTY
1	NTW75TPRBJBH12	1
2	STEM	
	TUBEM12X40X10	1
	HEXBOLTM10X70Z8.8	1
	WM10X21X2	2
	NM10GR8FULLZHT	1

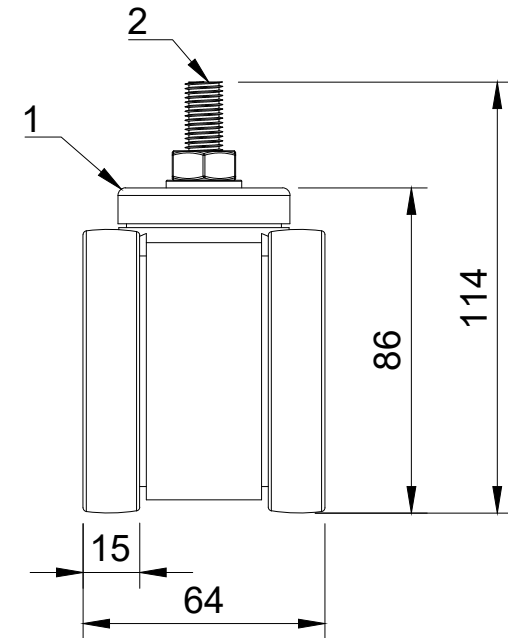

UNLESS OTHERWISE SPECIFIED DIMENSIONS ARE IN MILLIMETRES

Unspecified Tolerances
Machining $\pm 0.25\text{mm}$
Fabrication $\pm 1\text{mm}$

DRAWING DISCLAIMER

COPYRIGHT OF THIS DRAWING IS RESERVED BY BIL GROUP LTD. IT IS NOT REPRODUCED, COPIED, OR DISCLOSED TO A THIRD PARTY EITHER WHOLLY OR IN PART WITHOUT THE CONSENT IN WRITING OF BIL GROUP LTD

	NAME	DATE
DRAWN BY	Matt	10/11/23
APPROVED BY	Kevin	10/11/23
SCALE	1:2	
WEIGHT	0.368kg	

		BIL Group Ltd Porte Marsh Road Calne, Wiltshire, SN11 9BW United Kingdom Tel +44 (0)1249 822 222 www.bilgroup.co.uk	
		DWG NO.	REV
NTW75TPRBJSWBST		2	
NTW75TPRBJSWBST		SHEET 1 OF 1	