

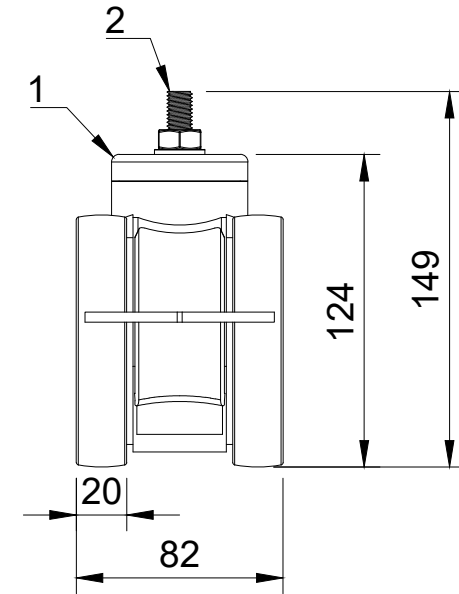

ITEM NO.	PART NUMBER	QTY
1	NTW100TPRBJBH12SWB	1
2	STEM	
	TUBEM12X50X10	1
	WM10X21X2	2
	BOLTM10X90Z8.8	1
	NM10GR8FULLZHT	1



UNLESS OTHERWISE SPECIFIED DIMENSIONS ARE IN MILLIMETRES  Unspecified Tolerances Machining ± 0.25mm Fabrication ± 1mm	DRAWING DISCLAIMER  COPYRIGHT OF THIS DRAWING IS RESERVED BY BIL GROUP LTD. IT IS NOT REPRODUCED, COPIED, OR DISCLOSED TO A THIRD PARTY EITHER WHOLLY OR IN PART WITHOUT THE CONSENT IN WRITING OF BIL GROUP LTD	NAME	DATE	 BIL Group Ltd Porte Marsh Road Calne, Wiltshire, SN11 9BW United Kingdom Tel +44 (0)1249 822 222 www.bilgroup.co.uk	
		DRAWN BY	Matt		13/11/23
		APPROVED BY	Kevin		13/11/23
		SCALE	1:3		
		WEIGHT	0.813kg		
		DWG NO.	REV		
		NTW100TPRBJSWBST	2		
		NTW100TPRBJSWBST	SHEET 1 OF 1		