

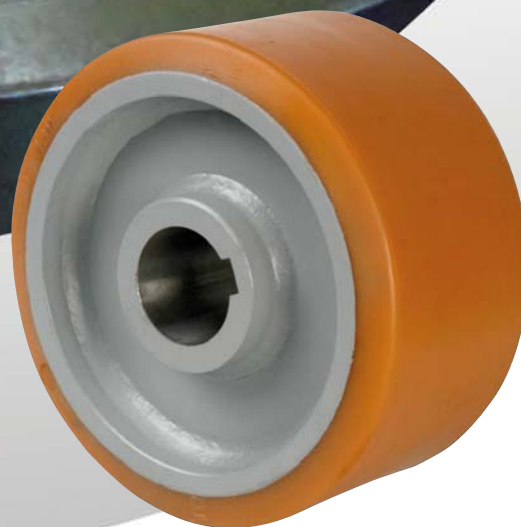

**High grade
polyurethane
designer
wheels**



Pilot bore,
key-way or
ball bearing



Castors & Wheels

Tel: 01249 822 222 www.bilcastors.co.uk



VULKOLLAN®



Castors & Wheels

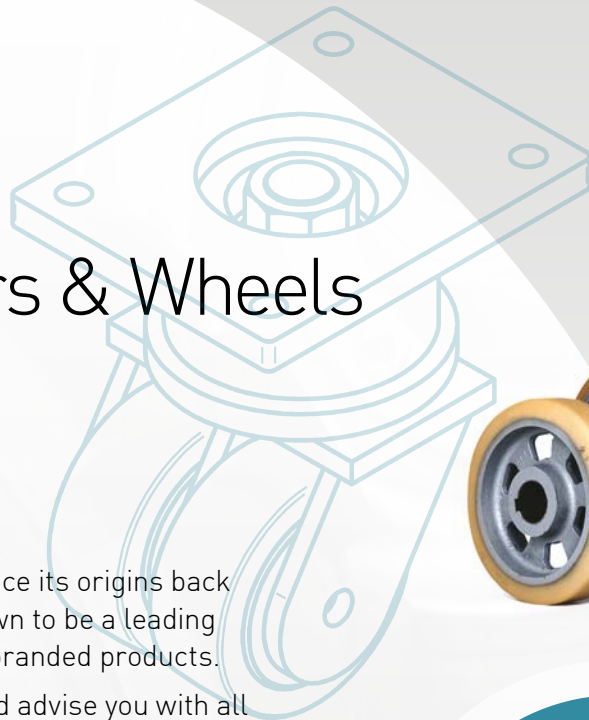

BIL Castors & Wheels can trace its origins back to 1972. Since then it has grown to be a leading manufacturer of its own BIL branded products.

BIL Group are able to help and advise you with all your product needs according to our vast market experience. Our externally-based field sales staff are supported by a dedicated team at our head office in Calne, providing excellent customer service and backup wherever and whenever you need it.

Our clients naturally require prompt availability on quality, tested product at competitive prices. Therefore at BIL we normally manufacture in large production batches, under strict quality controls, to achieve economies of scale and to ensure that we keep sufficient stock levels in the UK to service both our domestic and European customers.

BIL are confident that we can provide what you want, when you want it, competitively – a manufacturer offering distributor service with direct manufactured prices... now there's a first!



Quality, innovation and service

The philosophy and brand values for BIL are – quality, innovation and service. At BIL we are continually striving to further improve our product range and also the level of service to customers, both in the UK and across the EU... at BIL we never stand still.

Hi-grade polyurethane designer wheels...

Example applications.....	4
WVPT wheels 100–150mm diameter	6
WVPT wheels 200–300mm diameter	8
WVPT wheels 300mm diameter	10



projects

for bespoke solutions	11
-----------------------------	----



VULKOLLAN®



What is Vulkollan® ...and why use it?

Is there any difference between a Vulkollan® and an ordinary polyurethane tread?

Yes, Vulkollan® is a trade mark of Bayer AG and only carefully appointed manufacturers can sell this under licence. Only polyurethane produced with Desmodur 15 according to the Bayer formula can be called Vulkollan®. Vulkollan® exhibits outstanding properties due to the presence of Desmodur 15, other polyurethanes use isocyanides of inferior quality. Vulkollan® is the most widely used polyurethane elastomer and has become the standard for highest quality – it is a warm-cast polyurethane which is superior to cold-cast ones. The title Vulkollan has wrongly been used as a generic name for polyurethanes whereas Vulkollan® is a trade mark for very special polyurethane for demanding specialist applications.

What are the benefits of using Vulkollan®?

Vulkollan® has a high tear-resistance compared to many standard polyurethanes – even when the tread is damaged. As one of the most durable polyurethanes on the market, Vulkollan® has an extremely high abrasion resistance and can last twice as long as traditional rubber compounds.

Vulkollan® is the preferred choice for drive wheel applications and it will ensure your equipment runs freely with very little maintenance. During the manufacturing process a special surface-treatment is applied which achieves an optimum chemical bonding to the metal core – ensuring the tread stays in place for the lifetime of the wheel.

high grade
polyurethane
wheels
designed for
industry

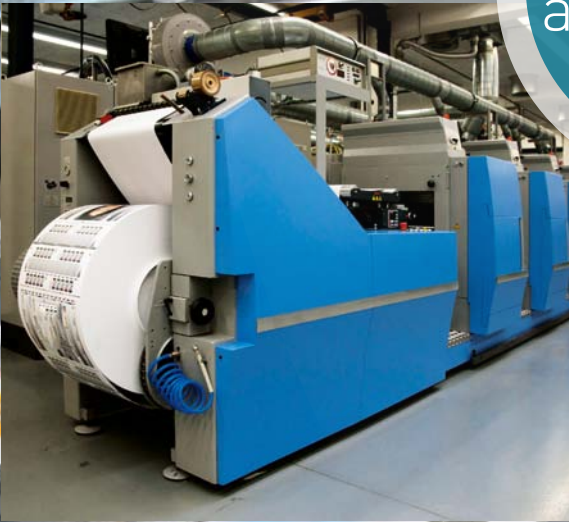

example applications

High grade polyurethane designer wheels...

...where performance counts



VULKOLLAN®



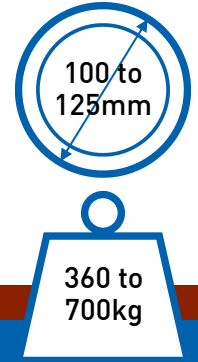

WVPT series wheels



BZH100WVPT

D 100mm T 40mm H 45mm B 55mm

Dynamic load at 6kph **360kg**; static load **450kg**

-  Standard plain bore size
12mm, 20mm, 25mm, 30mm, 35mm
-  Standard keyway bore size
15mm, 20mm, 25mm, 30mm, 35mm
-  Ball bearing size
15mm, 20mm

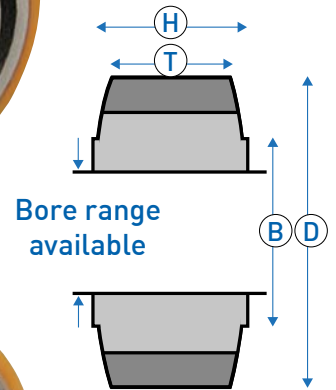
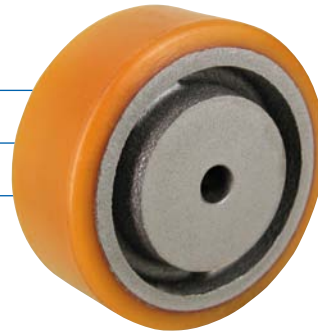
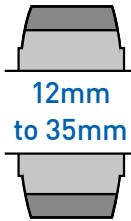



D Diameter
T Tread width
H Hub length
B Boss diameter

BZMH125WVPT

D 125mm T 35mm H 44mm B 43mm

Dynamic load at 6kph **380kg**; static load **480kg**

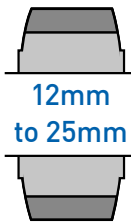

-  Standard plain bore size
12mm, 20mm, 25mm
-  Standard keyway bore size
15mm, 20mm, 25mm
-  Ball bearing size
15mm



BZH125WVPT

D 125mm T 50mm H 50mm B 57mm

Dynamic load at 6kph **500kg**; static load **700kg**

-  Standard plain bore size
20mm, 25mm, 30mm, 35mm, 40mm
-  Standard keyway bore size
20mm, 25mm, 30mm, 35mm, 40mm
-  Ball bearing size
20mm, 25mm

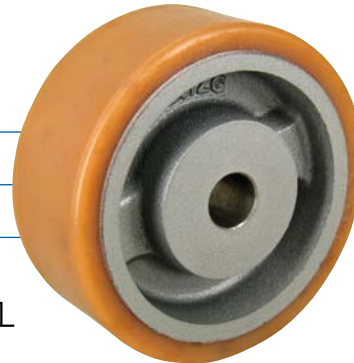
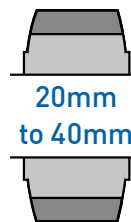

450-830kg

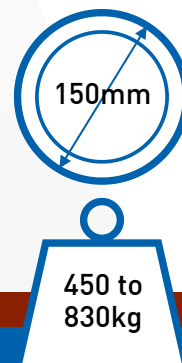

BZMH150WVPT

D 150mm T 35mm H 44mm B 43mm

Dynamic load at 6kph **450kg**; static load **570kg**



Standard plain bore size mm
15, 20, 25



Standard keyway bore size mm
15, 20, 25



Ball bearing size
15mm

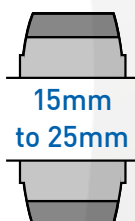

BZH150WVPT

D 150mm T 40mm H 40mm B 67mm

Dynamic load at 6kph **530kg**; static load **660kg**



Standard plain bore size mm
20, 25, 30, 35, 40, 50



Standard keyway bore size mm
20, 25, 30, 35, 40, 50



Ball bearing size mm
20, 25

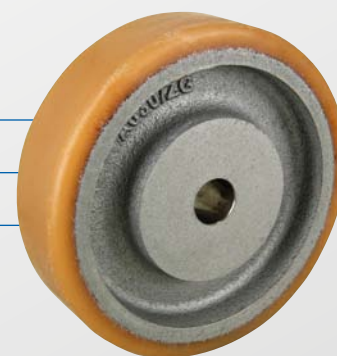
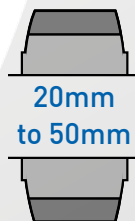

BZXH150WVPT

D 150mm T 50mm H 50mm B 67mm

Dynamic load at 6kph **660kg**; static load **830kg**



Standard plain bore size mm
20, 25, 30, 35, 40, 50



Standard keyway bore size mm
20, 25, 30, 35, 40, 50



Ball bearing size mm
20, 25

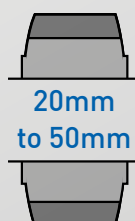

WVPT SERIES WHEELS



VULKOLLAN®



• Imperial sizes available on request

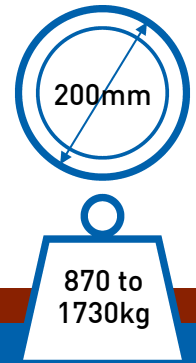

WVPT series wheels



BZMH200WVPT

D 200mm T 50mm H 60mm B 78mm

Dynamic load at 6kph **870kg**; static load **1080kg**

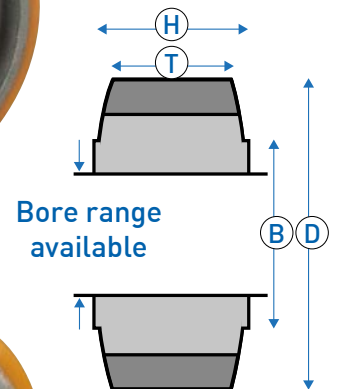
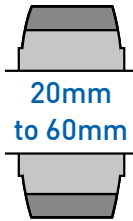

-  Standard plain bore size mm
20, 25, 30, 35, 40, 50, 60
-  Standard keyway bore size mm
20, 25, 30, 35, 40, 50, 60
-  Ball bearing size mm
20, 25, 30



BZH200WVPT

D 200mm T 65mm H 65mm B 85mm

Dynamic load at 6kph **1080kg**; static load **1350kg**

-  Standard plain bore size mm
25, 30, 35, 40, 50, 60
-  Standard keyway bore size mm
25, 30, 35, 40, 50, 60
-  Ball bearing size mm
25, 30

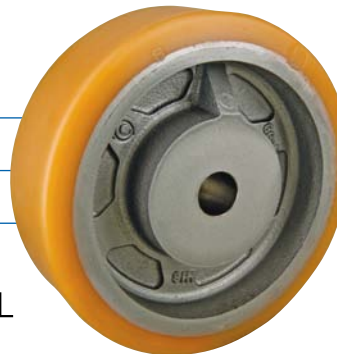
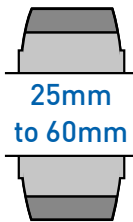



D Diameter
T Tread width
H Hub length
B Boss diameter

BZXH200WVPT

D 200mm T 80mm H 80mm B 82mm

Dynamic load at 6kph **1400kg**; static load **1730kg**

-  Standard plain bore size mm
30, 35, 40, 50
-  Standard keyway bore size mm
30, 35, 40, 50
-  Ball bearing size mm
25, 30

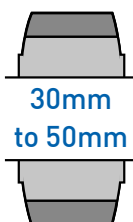

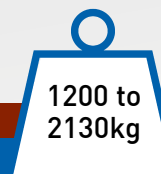
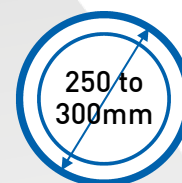

BZPMH250WVPT

D 250mm T 50mm H 60mm B 83mm

Dynamic load at 6kph **1350kg**; static load **1700kg**



Standard plain bore size **mm**
20, 25, 30, 35, 40, 50, 60

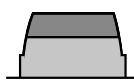

Standard keyway bore size **mm**
20, 25, 30, 35, 40, 50, 60

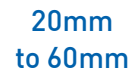

Ball bearing size **mm**
20, 25, 30



BZH250WVPT

D 250mm T 80mm H 80mm B 91mm

Dynamic load at 6kph **1700kg**; static load **2130kg**



Standard plain bore size **mm**
35, 40, 50, 60, 70

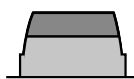

Standard keyway bore size **mm**
35, 40, 50, 60, 70

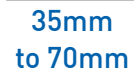

Ball bearing size **mm**
25, 30, 35



BZPMH300WVPT

D 300mm T 50mm H 60mm B 90mm

Dynamic load at 6kph **1200kg**; static load **1500kg**



Standard plain bore size **mm**
30, 35, 40, 50, 60

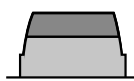

Standard keyway bore size **mm**
30, 35, 40, 50, 60

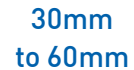

Ball bearing size
25mm



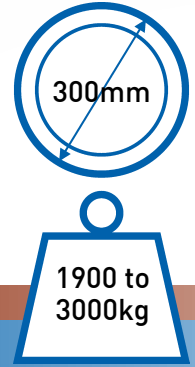

WVPT series wheels



BZH300WVPT

D 300mm T 80mm H 80mm B 96mm

Dynamic load at 6kph **1900kg**; static load **2400kg**

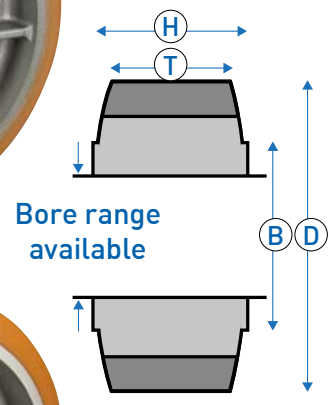
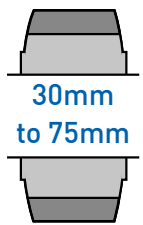

-  Standard plain bore size **mm**
30, 35, 40, 50, 60, 75
-  Standard keyway bore size **mm**
30, 35, 40, 50, 60, 75
-  Ball bearing size
30mm



BZXH300WVPT

D 300mm T 100mm H 100mm B 102mm

Dynamic load at 6kph **2400kg**; static load **3000kg**

-  Standard plain bore size **mm**
40, 50, 60, 75, 80
-  Standard keyway bore size **mm**
40, 50, 60, 75, 80
-  Ball bearing size **mm**
40, 50

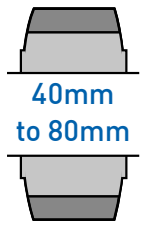

D Diameter
T Tread width
H Hub length
B Boss diameter

- Imperial sizes available on request

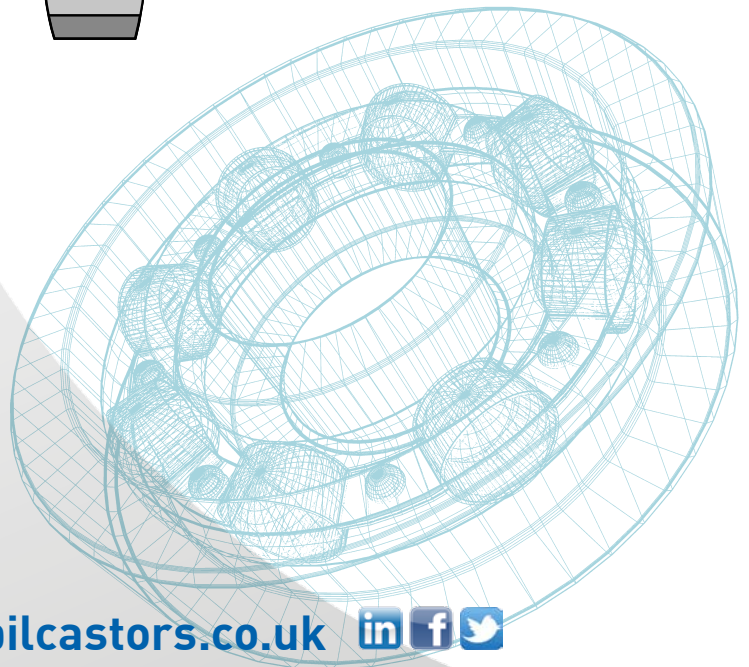

Quality manufacturing
Innovative solutions
Servicing your needs

For bespoke options...



BIL Castors & Wheels in exclusive partnership with DM Wheel Systems (Holland) are able to offer bespoke products to fit almost any requirement.

For bespoke items that require quality engineered product solutions from design stage right through to production.

Height restrictions? Non-standard plate sizes?
Extreme loads? BIL have the answer.

BIL are capable of manufacturing any castor to any specification up to a maximum load of 20,000kg... the possibilities are endless.

Full on-site technical support is available on request.



BIL and DM's project teams in design and development discussion

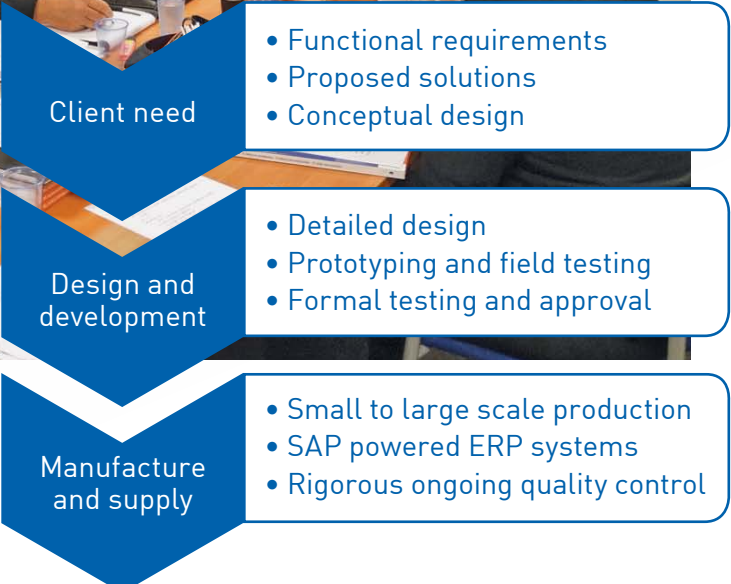

Call us today on 01249 822222 to find out more...

High grade polyurethane designer wheels

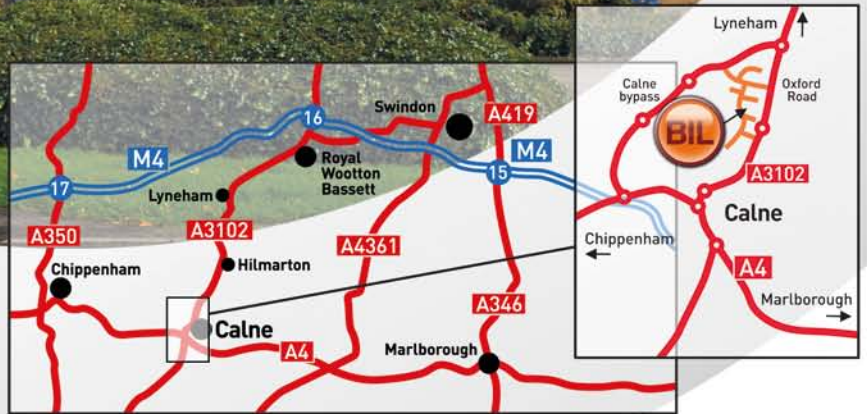

With our comprehensive range of over 10,000 different types of castors, wheels and rollers, plus plant and machinery-handling equipment – all manufactured by BIL – we are confident that we can promptly supply you with a product to match your specific requirements at a very competitive price.

Our current stock holding of components and finished goods at our European Storage, Assembly and Distribution facility based in Calne, UK is valued at over £2 million. Tried and tested, BIL is a brand that you can rely on for quality, innovation and service.

Call our sales team today to find out more!

BIL Castors & Wheels

A division of BIL Group
Porte Marsh Road, Calne
Wiltshire, SN11 9BW
United Kingdom

Tel: +44 (0)1249 822222

Fax: +44 (0)1249 822300

sales@bilgroup.eu

www.bilcastors.co.uk



Castors & Wheels



BIL® is a registered trademark of BIL Group Ltd