

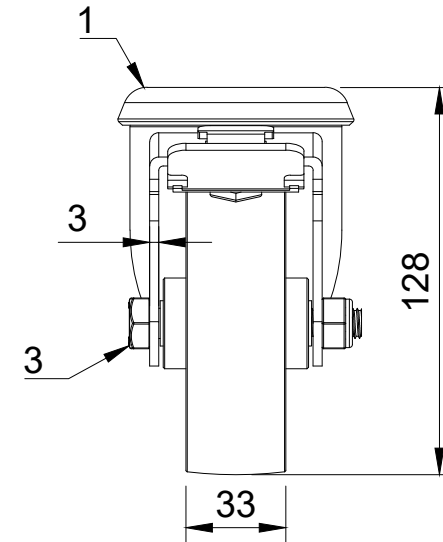

ITEM NO.	PRODUCT NUMBER	QTY
1	SSEH100ASBH12SWB	1
2	BZH100WNP61	1
3	AXLE KIT	
	TUBEM15X50SS	1
	BOLTM10X70A2	1
	NYLOCM10A2	1



UNLESS OTHERWISE SPECIFIED DIMENSIONS ARE IN MILLIMETRES Unspecified Tolerances Machining ± 0.25mm Fabrication ± 1mm	DRAWING DISCLAIMER COPYRIGHT OF THIS DRAWING IS RESERVED BY BIL GROUP LTD. IT IS NOT REPRODUCED, COPIED, OR DISCLOSED TO A THIRD PARTY EITHER WHOLLY OR IN PART WITHOUT THE CONSENT IN WRITING OF BIL GROUP LTD	NAME	DATE	 BIL Group Ltd Porte Marsh Road Calne, Wiltshire, SN11 9BW United Kingdom Tel +44 (0)1249 822 222 www.bilgroup.co.uk	DWG NO. SSEH100NPBH12SWB	REV 1	
		DRAWN BY	Matt				14/11/23
		APPROVED BY	Kevin				14/11/23
		SCALE	2:5				
		WEIGHT	1.014kg				
			SSEH100NPBH12SWB SHEET 1 OF 1				