

ITEM NO.	PRODUCT NUMBER	QTY
1	BZPH150AS	1
2	BZH150WENPBJM20	1
3	AXLE KIT	
	TH20X5X12	2
	HEXBOLTM12X90Z8.8	1
	NYLOCM12Z14MM	1

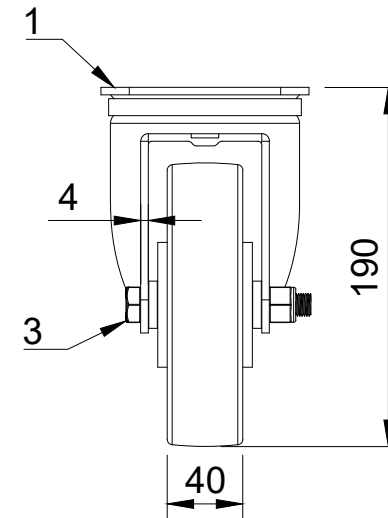

UNLESS OTHERWISE SPECIFIED DIMENSIONS ARE IN MILLIMETRES

Unspecified Tolerances
Machining ± 0.25mm
Fabrication ± 1mm

DRAWING DISCLAIMER

COPYRIGHT OF THIS DRAWING IS RESERVED BY BIL GROUP LTD. IT IS NOT REPRODUCED, COPIED, OR DISCLOSED TO A THIRD PARTY EITHER WHOLLY OR IN PART WITHOUT THE CONSENT IN WRITING OF BIL GROUP LTD

	NAME	DATE
DRAWN BY	Matt	02/10/23
APPROVED BY	Kevin	02/10/23
SCALE	1:4	
WEIGHT	2.251kg	

BIL Group Ltd
 Porte Marsh Road
 Calne, Wiltshire, SN11 9BW
 United Kingdom
 Tel +44 (0)1249 822 222
 www.bilgroup.co.uk



DWG NO.	BZPH150ENPBJ	REV 1
BZPH150ENPBJ		SHEET 1 OF 1