

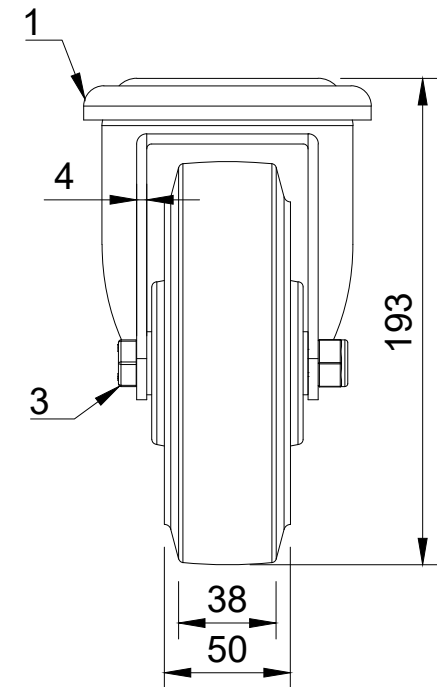

ITEM NO.	PART NUMBER	QTY
1	BZMM150ASBH16	1
2	BZH160WSRNBJM20	1
3	AXLE KIT	
	TH20X2X12	2
	HEXBOLTM12X80Z8.8	1
	NYLOCM12Z	1



UNLESS OTHERWISE SPECIFIED DIMENSIONS ARE IN MILLIMETRES  Unspecified Tolerances Machining ± 0.25mm Fabrication ± 1mm	<b>DRAWING DISCLAIMER</b>  COPYRIGHT OF THIS DRAWING IS RESERVED BY BIL GROUP LTD. IT IS NOT REPRODUCED, COPIED, OR DISCLOSED TO A THIRD PARTY EITHER WHOLLY OR IN PART WITHOUT THE CONSENT IN WRITING OF BIL GROUP LTD	<b>NAME</b> Matt	<b>DATE</b> 21/10/24	 BIL Group Ltd Porte Marsh Road Calne, Wiltshire, SN11 9BW United Kingdom Tel +44 (0)1249 822 222 www.bilgroup.co.uk	 VARLEY H Varley Ltd Unit 5 Century Park Pacific Rd, Broadheath, Altrincham, Cheshire WA14 5BJ Tel +44 (0)161 928 9617 www.varley-castors.co.uk
		<b>DRAWN BY</b> Matt	<b>DATE</b> 21/10/24		
		<b>APPROVED BY</b> Chris	<b>DATE</b> 21/10/24		
		<b>SCALE</b> 1:3			
		<b>WEIGHT</b> 2.577kg			
		<b>DWG NO.</b> BZMM160SRNBJBH16		<b>REV</b> 1	
		BZMM160SRNBJBH16		SHEET 1 OF 1	