

ITEM NO	PART NUMBER	QTY
1	BZLR40AS	1
2	BZXH40WNYM15	1
3	AXLE KIT	
	TUBEM15X40X10	1
	BOLTM10X55Z8.8	1
	NYLOCM10Z	1

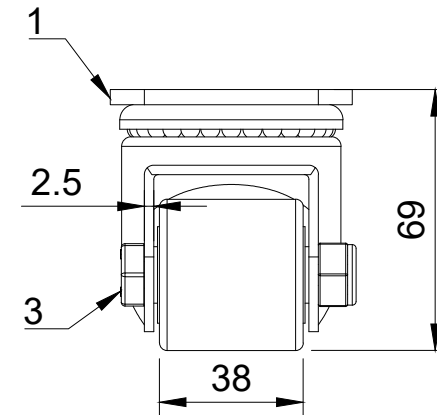

UNLESS OTHERWISE SPECIFIED DIMENSIONS ARE IN MILLIMETRES

Unspecified Tolerances
Machining ± 0.25mm
Fabrication ± 1mm

DRAWING DISCLAIMER

COPYRIGHT OF THIS DRAWING IS RESERVED BY BIL GROUP LTD. IT IS NOT REPRODUCED, COPIED, OR DISCLOSED TO A THIRD PARTY EITHER WHOLLY OR IN PART WITHOUT THE CONSENT IN WRITING OF BIL GROUP LTD

	NAME	DATE
DRAWN BY	Matt	30/01/24
APPROVED BY	Kevin	30/01/24
SCALE	1:2	
WEIGHT	0.579kg	

BILGroup

BIL Group Ltd
Porte Marsh Road
Calne, Wiltshire, SN11 9BW
United Kingdom
Tel +44 (0)1249 822 222
www.bilgroup.co.uk

DWG NO. **BZLR40NY**

REV **1**

BZLR40NY SHEET 1 OF 1