

ITEM NO.	PART NUMBER	QTY
1	BZJF150AS	1
2	BZV150WNY5	1
3	AXLE KIT	
	TUBEM20X60	1
	WP20X40X2	2
	HEXBOLTM12X90Z8.8	1
	NYLOCM12Z14MM	1

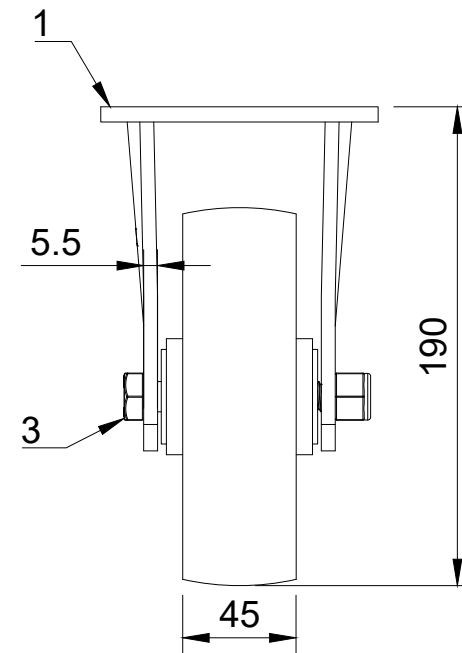

UNLESS OTHERWISE SPECIFIED DIMENSIONS ARE IN MILLIMETRES

Unspecified Tolerances  
Machining ± 0.25mm  
Fabrication ± 1mm

DRAWING DISCLAIMER

COPYRIGHT OF THIS DRAWING IS RESERVED BY BIL GROUP LTD. IT IS NOT REPRODUCED, COPIED, OR DISCLOSED TO A THIRD PARTY EITHER WHOLLY OR IN PART WITHOUT THE CONSENT IN WRITING OF BIL GROUP LTD

	NAME	DATE
DRAWN BY	Matt	30/04/24
APPROVED BY	Kevin	30/04/24
SCALE	1:3	
WEIGHT	1.962kg	

	BIL Group Ltd Porte Marsh Road Calne, Wiltshire, SN11 9BW United Kingdom Tel +44 (0)1249 822 222 www.bilgroup.co.uk			H Varley Ltd Unit 5 Century Park Pacific Rd, Broadheath, Altrincham, Cheshire WA14 5BJ Tel +44 (0)161 928 9617 www.varley-castors.co.uk	
	DWG NO.	BZJF150NY		REV	1
			BZJF150NY		SHEET 1 OF 1