

ITEM NO.	PART NUMBER	QTY
1	BZH100ASBRLP	1
2	BZH100WNY61	1
3	AXLE KIT	
	TUBEM15X50	1
	BOLTM10X80Z8.8	1
	NYLOCM10Z	1

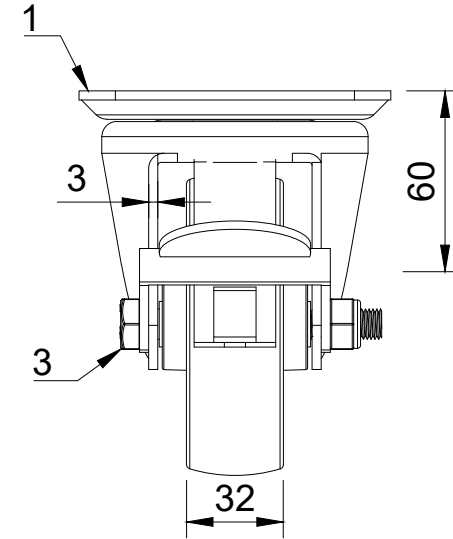

UNLESS OTHERWISE SPECIFIED DIMENSIONS ARE IN MILLIMETRES

Unspecified Tolerances
Machining ± 0.25mm
Fabrication ± 1mm

DRAWING DISCLAIMER

COPYRIGHT OF THIS DRAWING IS RESERVED BY BIL GROUP LTD. IT IS NOT REPRODUCED, COPIED, OR DISCLOSED TO A THIRD PARTY EITHER WHOLLY OR IN PART WITHOUT THE CONSENT IN WRITING OF BIL GROUP LTD

	NAME	DATE
DRAWN BY	Matt	14/02/24
APPROVED BY	Kevin	14/02/24
SCALE	2:5	
WEIGHT	1.043kg	

BILGroup

BIL Group Ltd
Porte Marsh Road
Calne, Wiltshire, SN11 9BW
United Kingdom
Tel +44 (0)1249 822 222
www.bilgroup.co.uk

DWG NO.	BZH100NYLPBR	REV	1
BZH100NYLPBR		SHEET 1 OF 1	