

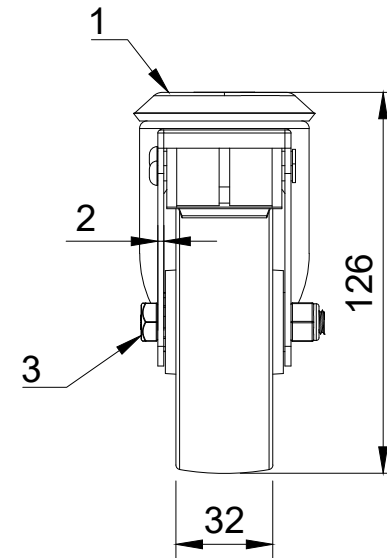

ITEM NO.	PRODUCT NUMBER	QTY
1	BZBC100ASBH12SWB	1
2	WPL4RBM12	1
3	AXLE KIT	
	TUBEM12X40	1
	HEXBOLTM8X55Z8.8	1
	NYLOCM8Z	1



UNLESS OTHERWISE SPECIFIED DIMENSIONS ARE IN MILLIMETRES Unspecified Tolerances Machining ± 0.25mm Fabrication ± 1mm	DRAWING DISCLAIMER COPYRIGHT OF THIS DRAWING IS RESERVED BY BIL GROUP LTD. IT IS NOT REPRODUCED, COPIED, OR DISCLOSED TO A THIRD PARTY EITHER WHOLLY OR IN PART WITHOUT THE CONSENT IN WRITING OF BIL GROUP LTD	NAME Matt	DATE 22/09/23		BIL Group Ltd Porte Marsh Road Calne, Wiltshire, SN11 9BW United Kingdom Tel +44 (0)1249 822 222 www.bilgroup.co.uk		
		DRAWN BY Matt	DATE 22/09/23		DWG NO. BZBC100PLBBH12SWB	REV 1	
		APPROVED BY Chris	DATE 22/09/23	BZBC100PLBBH12SWB		SHEET 1 OF 1	
		SCALE 2:5	WEIGHT 0.575kg				