

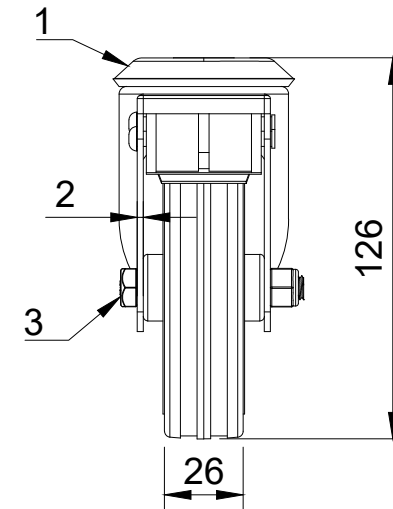

ITEM NO.	PRODUCT NUMBER	QTY
1	BZBC100ASBH12SWB	1
2	BZML100WBSRB	1
3	AXLE KIT	
	TUBEM12X40	1
	HEXBOLTM8X55Z8.8	1
	NYLOCM8Z	1



UNLESS OTHERWISE SPECIFIED DIMENSIONS ARE IN MILLIMETRES  Unspecified Tolerances Machining ± 0.25mm Fabrication ± 1mm	<b>DRAWING DISCLAIMER</b>  COPYRIGHT OF THIS DRAWING IS RESERVED BY BIL GROUP LTD. IT IS NOT REPRODUCED, COPIED, OR DISCLOSED TO A THIRD PARTY EITHER WHOLLY OR IN PART WITHOUT THE CONSENT IN WRITING OF BIL GROUP LTD	NAME	DATE	 BIL Group Ltd Porte Marsh Road Calne, Wiltshire, SN11 9BW United Kingdom Tel +44 (0)1249 822 222 www.bilgroup.co.uk	DWG NO. <b>BZBC100BSBBH12SWB</b>	REV <b>1</b>	
		DRAWN BY	Matt				09/10/23
		APPROVED BY	Kevin				09/10/23
		SCALE	2:5				
		WEIGHT	0.746kg				
			BZBC100BSBBH12SWB SHEET 1 OF 1				