

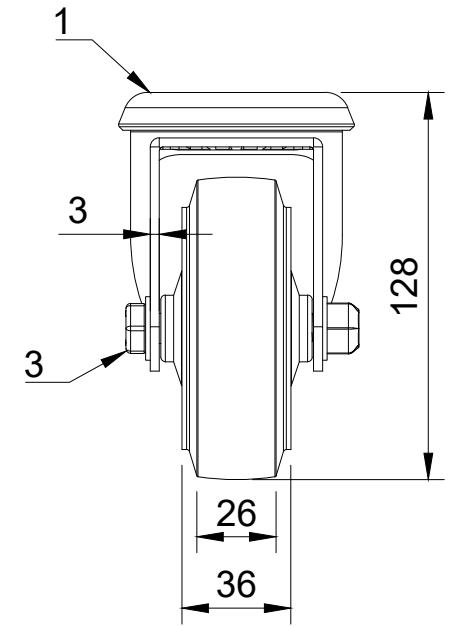

ITEM NO.	PART NUMBER	QTY
1	BLKH100ASBH12	1
2	BZMM100WSRNBH/BLK	1
3	AXLE KIT	
	HUBCAPM10X49/RN	2
	WM10X21X1BLK	2
	BOLTM10X70BLK	1
	NM10STOVERNUT	1



UNLESS OTHERWISE SPECIFIED DIMENSIONS ARE IN MILLIMETRES  Unspecified Tolerances Machining ± 0.25mm Fabrication ± 1mm	<b>DRAWING DISCLAIMER</b>  COPYRIGHT OF THIS DRAWING IS RESERVED BY BIL GROUP LTD. IT IS NOT REPRODUCED, COPIED, OR DISCLOSED TO A THIRD PARTY EITHER WHOLLY OR IN PART WITHOUT THE CONSENT IN WRITING OF BIL GROUP LTD	<b>NAME</b> Matt	<b>DATE</b> 13/03/24		BIL Group Ltd Porte Marsh Road Calne, Wiltshire, SN11 9BW United Kingdom Tel +44 (0)1249 822 222 www.bilgroup.co.uk		
		<b>DRAWN BY</b> Matt	<b>DATE</b> 13/03/24		<b>DWG NO.</b> BLKH100SRNBJBH12/BLK	<b>REV</b> 1	
		<b>APPROVED BY</b> Kevin	<b>DATE</b> 13/03/24	BLKH100SRNBJBH12/BLK		SHEET 1 OF 1	
		<b>SCALE</b> 2:5	<b>WEIGHT</b> 0.852kg				