

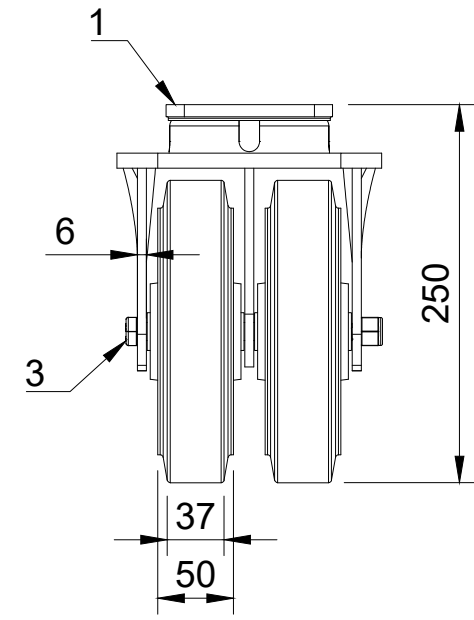

ITEM NO.	PART NUMBER	QTY
1	2BZK200AS	1
2	BZKL200WCUBJM20	2
3	AXLE KIT	
	TH20X2X12	4
	BOLTM12X160Z8.8	1
	NYLOCM12Z14MM	1



UNLESS OTHERWISE SPECIFIED DIMENSIONS ARE IN MILLIMETRES  Unspecified Tolerances Machining ± 0.25mm Fabrication ± 1mm	<b>DRAWING DISCLAIMER</b>  COPYRIGHT OF THIS DRAWING IS RESERVED BY BIL GROUP LTD. IT IS NOT REPRODUCED, COPIED, OR DISCLOSED TO A THIRD PARTY EITHER WHOLLY OR IN PART WITHOUT THE CONSENT IN WRITING OF BIL GROUP LTD	<b>NAME</b> Matt	<b>DATE</b> 15/01/24		BIL Group Ltd Porte Marsh Road Calne, Wiltshire, SN11 9BW United Kingdom Tel +44 (0)1249 822 222 www.bilgroup.co.uk
		<b>DRAWN BY</b> Matt	<b>DATE</b> 15/01/24		
		<b>APPROVED BY</b> Kevin	<b>DATE</b> 15/01/24	<b>DWG NO.</b> 2BZK200CUBJ	<b>REV</b> 1
		<b>SCALE</b> 1:5		2BZK200CUBJ	
		<b>WEIGHT</b> 11.301kg		SHEET 1 OF 1	