

ITEM NO.	PRODUCT NUMBER	QTY
1	2BZD75ASBH12	1
2	BZL75WPL	2
3	AXLE KIT	
	TUBEM8X55	1
	WP8X25X2	1
	BOLTM6X70Z8.8	1
	NYLOCM6Z	1

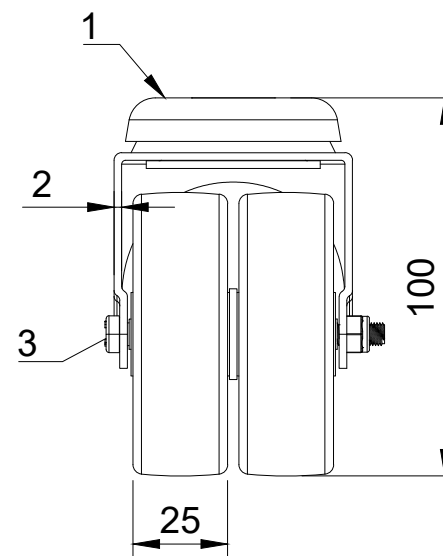

UNLESS OTHERWISE SPECIFIED DIMENSIONS ARE IN MILLIMETRES

Unspecified Tolerances  
Machining ± 0.25mm  
Fabrication ± 1mm

DRAWING DISCLAIMER

COPYRIGHT OF THIS DRAWING IS RESERVED BY BIL GROUP LTD. IT IS NOT REPRODUCED, COPIED, OR DISCLOSED TO A THIRD PARTY EITHER WHOLLY OR IN PART WITHOUT THE CONSENT IN WRITING OF BIL GROUP LTD

	NAME	DATE
DRAWN BY	Matt	22/08/23
APPROVED BY	Kevin	22/08/23
SCALE	1:2	
WEIGHT	0.426kg	

**BILGroup**

BIL Group Ltd  
Porte Marsh Road  
Calne, Wiltshire, SN11 9BW  
United Kingdom  
Tel +44 (0)1249 822 222  
www.bilgroup.co.uk

DWG NO. **2BZD75PLBH12**

REV **1**

**2BZD75PLBH12** SHEET 1 OF 1