

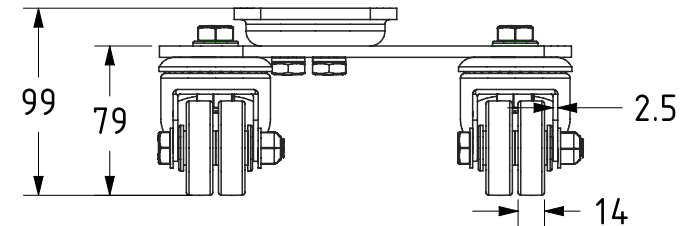

| ITEM NO. | PART NUMBER | QTY |
|----------|-------------------|-----|
| 1 | BZSKLAS | 1 |
| 2 | BLKLR50NYBH12 | 3 |
| 3 | FITTINGS | |
| | WM12X24X2Z | 3 |
| | BOLTM12X35SETZ8.8 | 3 |
| | NYLOCM12Z14MM | 3 |

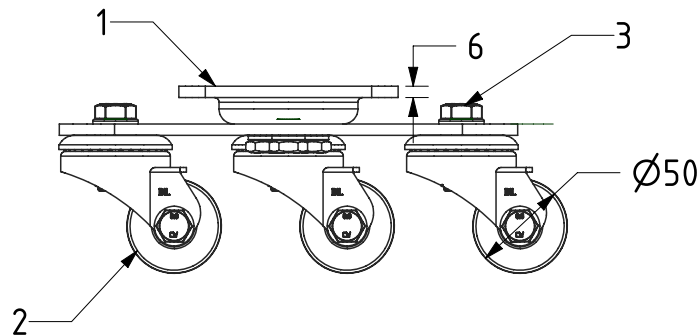

| | | | | | | | |
|---|--|-------------|---------|----------|---|-------------|--------------|
| UNLESS OTHERWISE SPECIFIED DIMENSIONS ARE IN MILLIMETRES Unspecified Tolerances Machining ± 0.25mm Fabrication ± 1mm | DRAWING DISCLAIMER COPYRIGHT OF THIS DRAWING IS RESERVED BY BIL GROUP LTD. IT IS ISSUED ON CONDITION THAT IT IS NOT REPRODUCED, COPIED, OR DISCLOSED TO A THIRD PARTY EITHER WHOLLY OR IN PART WITHOUT THE CONSENT IN WRITING OF BIL GROUP LTD. | | NAME | DATE |  BIL Group Ltd, Porte Marsh Road, Calne, Wiltshire, SN11 9BW, United Kingdom Tel +44 (0)1249 822 222 www.bilgroup.co.uk | | |
| | | DRAWN | Matt | 10/03/23 | | | |
| | | APPROVED BY | Kevin | 10/03/23 | DWG NO. | 2BLKSKL50NY | REV 1 |
| | | SCALE | 1:4 | | | | |
| | | WEIGHT | 3.629kg | | | 2BLKSKL50NY | SHEET 1 OF 1 |