

ITEM NO.	PART NUMBER	QTY
1	V GROOVE CAST IRON WHEEL	1
2	BSM25XM35	1
3	BEARINGSPACER47X2	2
4	BEARING6005	2

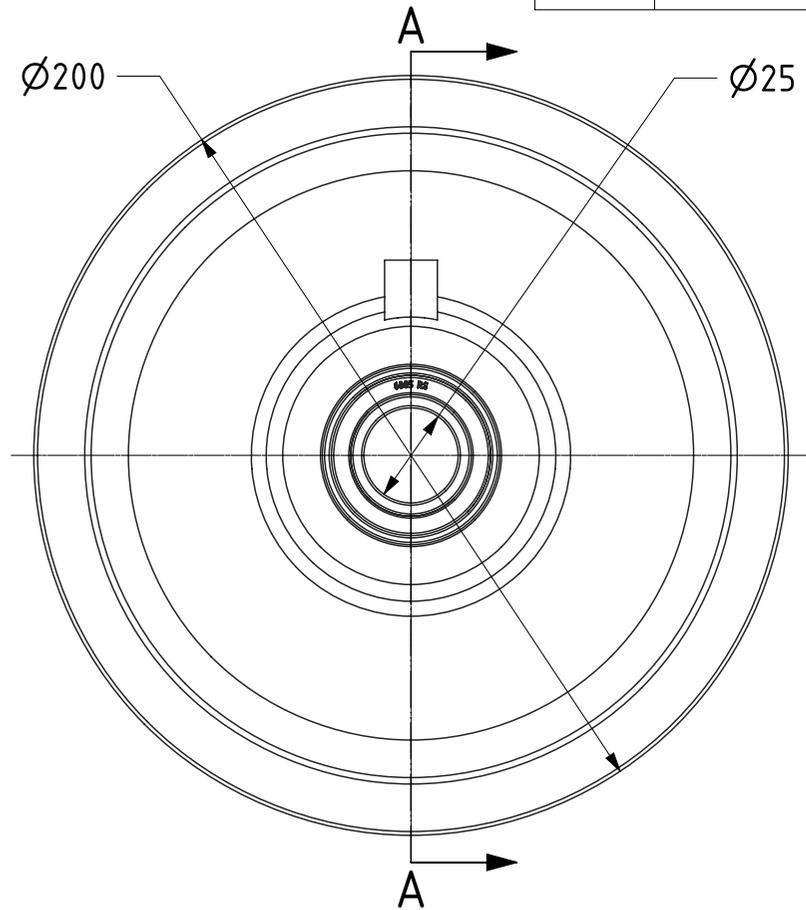
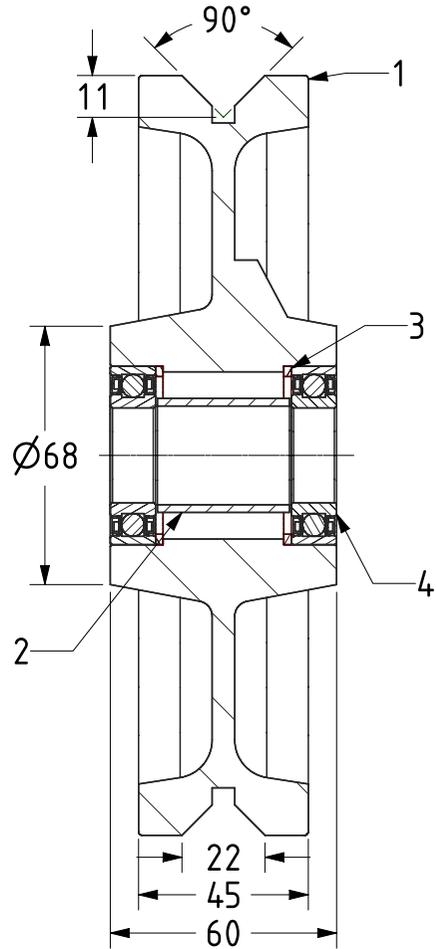

UNLESS OTHERWISE SPECIFIED DIMENSIONS ARE IN MILLIMETRES

Unspecified Tolerances
Machining $\pm 0.25\text{mm}$
Fabrication $\pm 1\text{mm}$

DRAWING DISCLAIMER

COPYRIGHT OF THIS DRAWING IS RESERVED BY BIL GROUP LTD. IT IS ISSUED ON CONDITION THAT IT IS NOT REPRODUCED, COPIED, OR DISCLOSED TO A THIRD PARTY EITHER WHOLLY OR IN PART WITHOUT THE CONSENT IN WRITING OF BIL GROUP LTD.

	NAME	DATE
DRAWN	Matt	21/03/23
APPROVED BY	Kevin	21/03/23
SCALE	1:2	
WEIGHT	4.89kg	

BILGroup

BIL Group Ltd,
Porte Marsh Road,
Calne, Wiltshire, SN11 9BW,
United Kingdom
Tel +44 (0)1249 822 222
www.bilgroup.co.uk

DWG NO.	BZH200WCVBJM25	REV	1
BZH200WCVBJM25		SHEET 1 OF 1	