

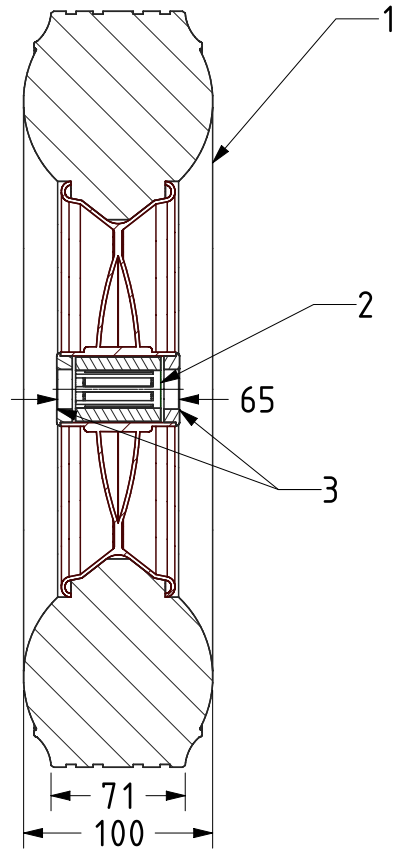

ITEM NO.	PART NUMBER	QTY
1	BZWMKL4003561RED	1
2	RBM20X35X45	1
3	RETAINER20X35X2	2

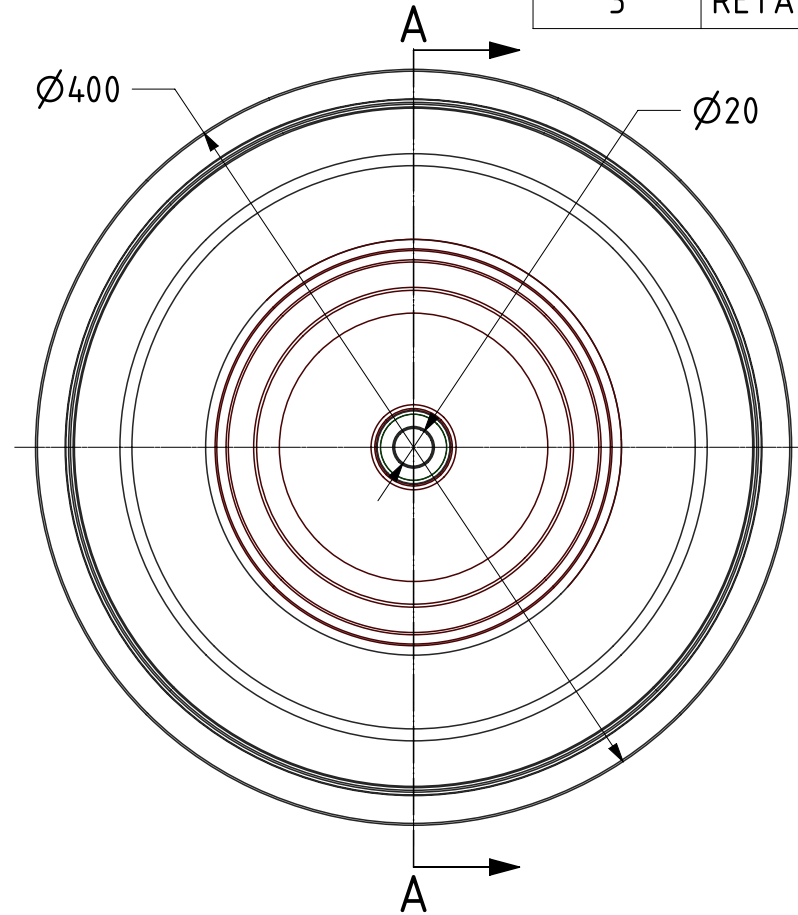

SECTION A-A



UNLESS OTHERWISE SPECIFIED DIMENSIONS ARE IN MILLIMETRES

Unspecified Tolerances  
Machining  $\pm 0.25\text{mm}$   
Fabrication  $\pm 1\text{mm}$

DRAWING DISCLAIMER

COPYRIGHT OF THIS DRAWING IS RESERVED BY BIL GROUP LTD. IT IS ISSUED ON CONDITION THAT IT IS NOT REPRODUCED, COPIED, OR DISCLOSED TO A THIRD PARTY EITHER WHOLLY OR IN PART WITHOUT THE CONSENT IN WRITING OF BIL GROUP LTD.

	NAME	DATE
DRAWN	Matt	01/12/21
APPROVED BY	Kevin	02/12/21
SCALE	1:4	
WEIGHT	10.028kg	

BIL Group Ltd, Porte Marsh Road, Calne  
Wiltshire, SN11 9BW, United Kingdom  
Tel +44 (0)1249 822 222 Fax: +44 (0)1249 822 300  
www.bilgroup.co.uk

DWG NO.	BZWMKLR4002066RED	REV	1
BZWMKLR4002066/RED SHEET 1 OF 1			