

ITEM NO.	PART NUMBER	QTY
1	BZMH80WSRNB	1
2	HUBCAPM10X49RN	2

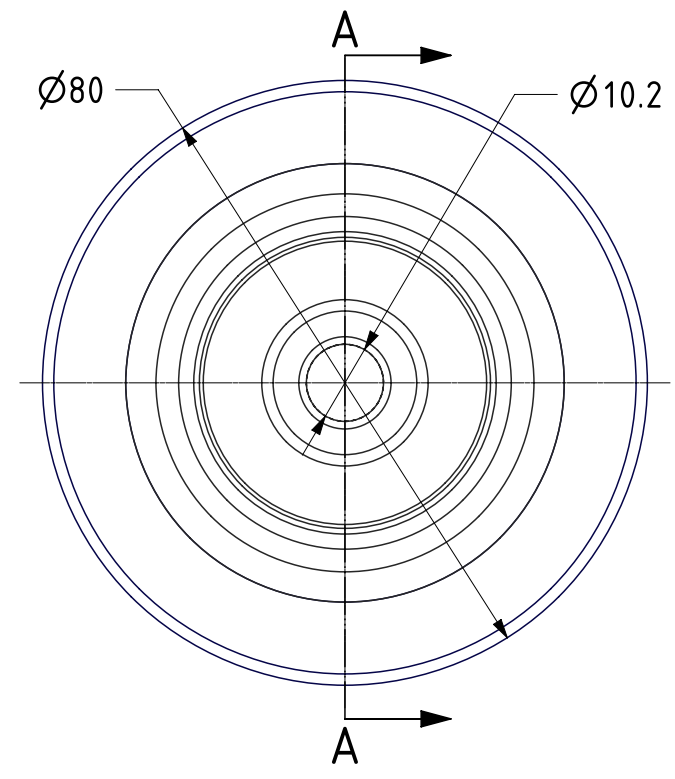
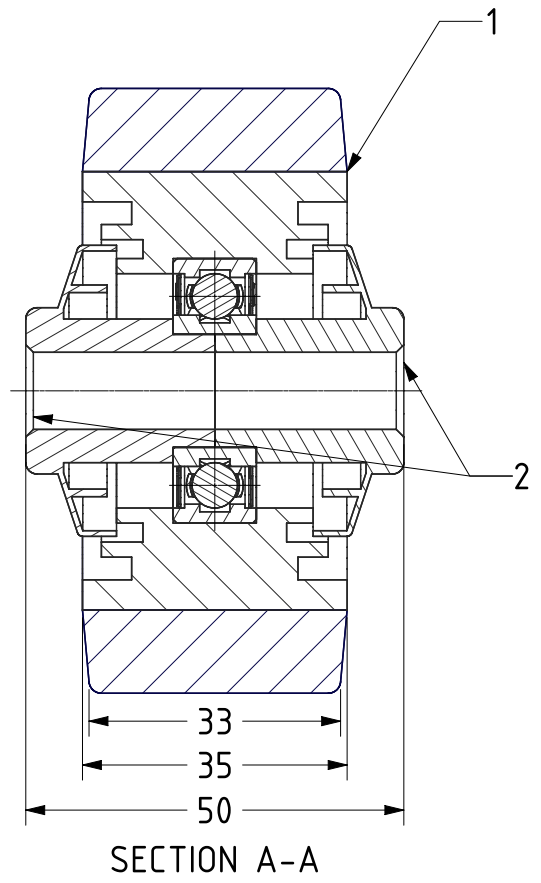

UNLESS OTHERWISE SPECIFIED DIMENSIONS ARE IN MILLIMETRES

Unspecified Tolerances  
Machining ± 0.25mm  
Fabrication ± 1mm

DRAWING DISCLAIMER

COPYRIGHT OF THIS DRAWING IS RESERVED BY BIL GROUP LTD. IT IS ISSUED ON CONDITION THAT IT IS NOT REPRODUCED, COPIED, OR DISCLOSED TO A THIRD PARTY EITHER WHOLLY OR IN PART WITHOUT THE CONSENT IN WRITING OF BIL GROUP LTD.

	NAME	DATE
DRAWN	Matt	21/12/21
APPROVED BY	Kevin	21/12/21
SCALE	1:1	
WEIGHT	0.205kg	



BIL Group Ltd, Porte Marsh Road, Calne  
Wiltshire, SN11 9BW, United Kingdom  
Tel +44 (0)1249 822 222 Fax: +44 (0)1249 822 300  
www.bilgroup.co.uk

DWG NO.	BZH80WSRNB	REV	1
BZH80WSRNB		SHEET 1 OF 1	