

**DRAWING DISCLAIMER**  
 COPYRIGHT OF THIS DRAWING IS RESERVED BY BIL GROUP LTD. IT IS ISSUED ON CONDITION THAT IT IS NOT REPRODUCED, COPIED, OR DISCLOSED TO A THIRD PARTY EITHER WHOLLY OR IN PART WITHOUT THE CONSENT IN WRITING OF BIL GROUP LTD.

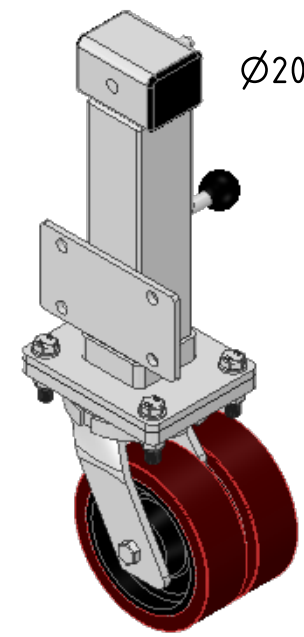

**Description:**  
 JAZHD2X200PTBJWT  
 Side plate fixing fabricated zinc plated jacking unit fitted with a twin wheel 200mm swivel castor with 2 x polyurethane on cast iron centred ball bearing wheels, Tread width 60mm x 2 plate size 200mm x 110mm, hole centres 135mm x 80mm, height 681m/831mm, maximum lift is 150mm. Load capacity 2600kg. Please note Jacking castors are rated on a different principal to other castors and we recommend the total lifted load is divided over just 2 jacking units. f When jacked up to the height please beware of any obstacles as a sudden shock could result in the inner square tube bending around the outer tube.

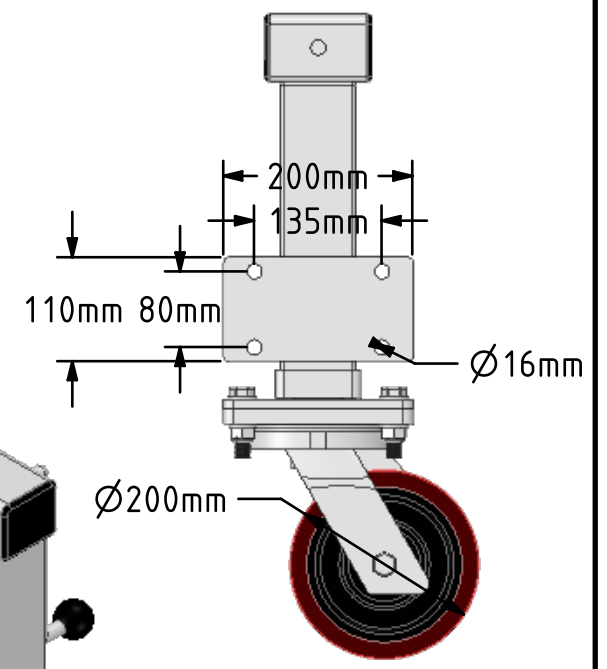
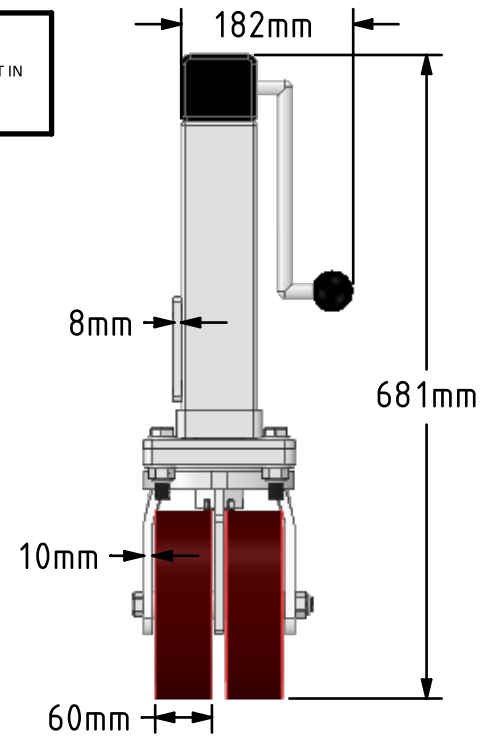
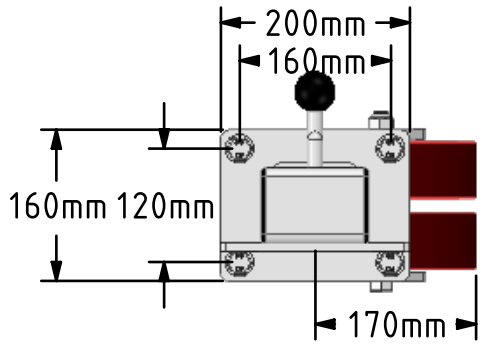

	NAME	DATE
DRAWN	Matt	30/04/19
APPROVED BY	Chris	30/04/19
SCALE	1:8	30/04/19
WEIGHT	32.107kg	30/04/19

**BIL** Group Ltd, Porte Marsh Road, Calne  
 Wiltshire, SN11 9BW, United Kingdom  
 Tel +44 (0)1249 822 222 Fax: +44 (0)1249 822 300  
 www.bilgroup.co.uk

TITLE  
**JAZHD2X200PTBJWT**

UNLESS OTHERWISE SPECIFIED DIMENSIONS ARE IN MILLIMETRES  
 Unspecified Tolerances  
 Machining ± 0.25mm  
 Fabrication ± 1mm

SIZE	DWG NO.	REV
A4	BILCW03JAZHD2X200PTBJWT_01	1

FILE NAME BILCW03JAZHD2X200PTBJWT\_01.PDF SHEET 1 OF 1