

DRAWING DISCLAIMER
 COPYRIGHT OF THIS DRAWING IS RESERVED BY BIL GROUP LTD. IT IS ISSUED ON CONDITION THAT IT IS NOT REPRODUCED, COPIED, OR DISCLOSED TO A THIRD PARTY EITHER WHOLLY OR IN PART WITHOUT THE CONSENT IN WRITING OF BIL GROUP LTD.

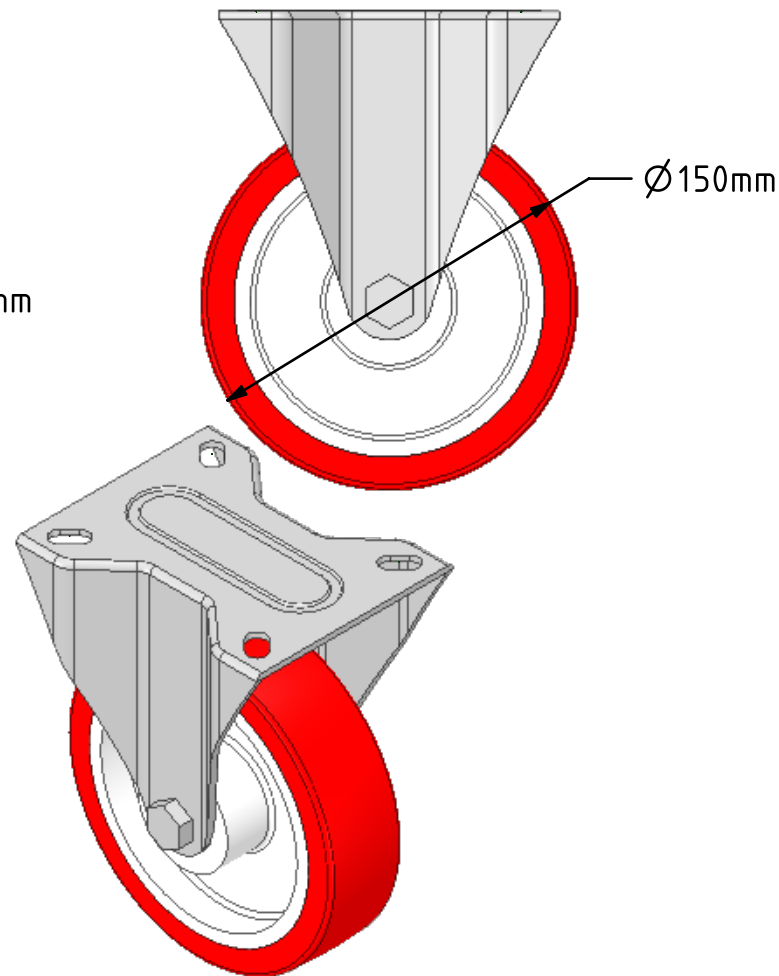

Description:
 SSMMF150NPB

Grade 304 Pressed stainless steel fixed castor with a top plate fixing fitted with a red polyurethane white nylon centred wheel with roller bearing and total lock brake. Wheel diameter 150mm, tread width 40mm, overall height 190mm, top plate 135mm x 110mm, hole centres 105mm x 80mm. Load capacity 400kg.

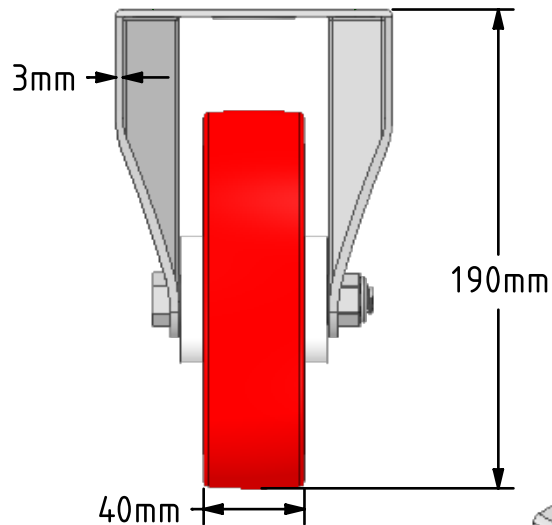
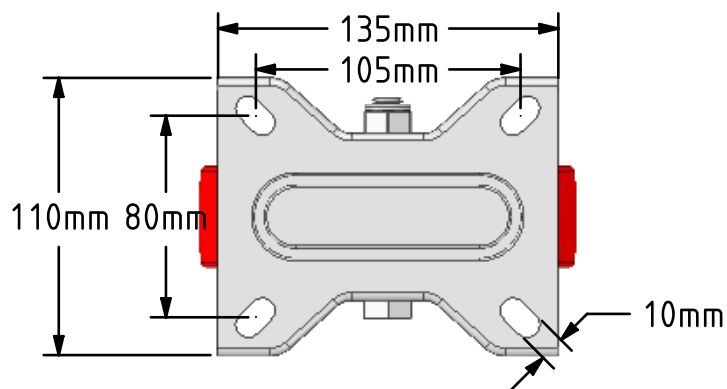

	NAME	DATE
DRAWN	Matt	06/03/19
APPROVED BY	Chris	06/03/19
SCALE	1:3	06/03/19
WEIGHT	1.42kg	06/03/19



BIL Group Ltd, Porte Marsh Road, Calne
 Wiltshire, SN11 9BW, United Kingdom
 Tel +44 (0)1249 822 222 Fax: +44 (0)1249 822 300
 www.bilgroup.co.uk

TITLE

SSMMF150NPB

UNLESS OTHERWISE SPECIFIED DIMENSIONS ARE IN MILLIMETRES

Unspecified Tolerances
 Machining ± 0.25mm
 Fabrication ± 1mm

SIZE	DWG NO.	REV
A4	BILCW03SSMMF150NPB_02	2

FILE NAME BILCW03SSMMF150NPB_02.PDF SHEET 1 OF 1