

DRAWING DISCLAIMER  
 COPYRIGHT OF THIS DRAWING IS RESERVED BY BIL GROUP LTD. IT IS ISSUED ON CONDITION THAT IT IS NOT REPRODUCED, COPIED, OR DISCLOSED TO A THIRD PARTY EITHER WHOLLY OR IN PART WITHOUT THE CONSENT IN WRITING OF BIL GROUP LTD.

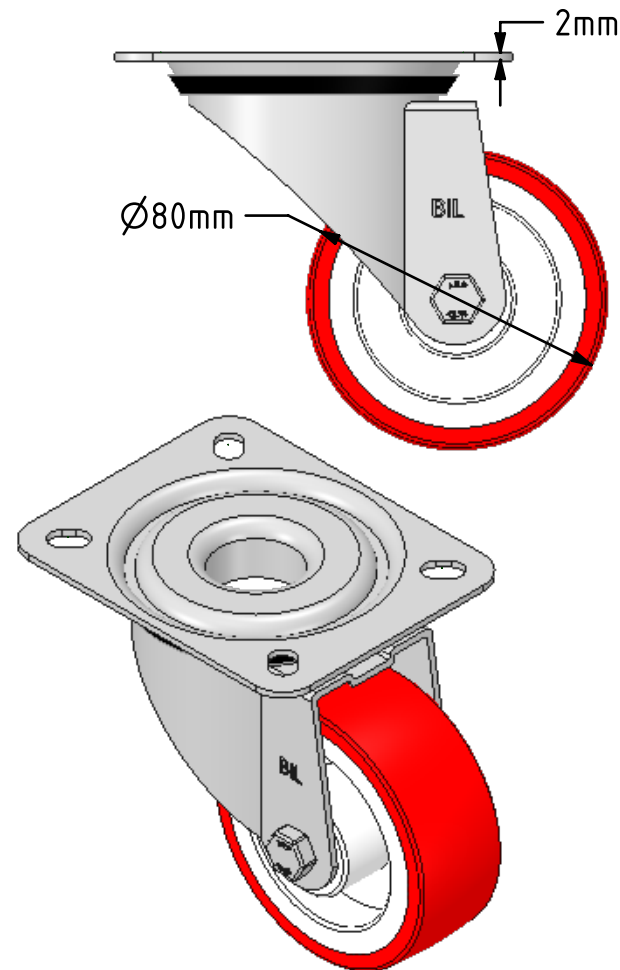

Description:  
 SSMM80NPB

Grade 304 Pressed stainless steel swivel castor with top plate fixing fitted with red polyurethane tyre on white nylon centred wheel with roller bearing. Wheel diameter 80mm, tread width 30mm, overall height 105mm, top plate 105mm x 85mm, hole centres 80mm x 60mm. Load capacity 150kg.

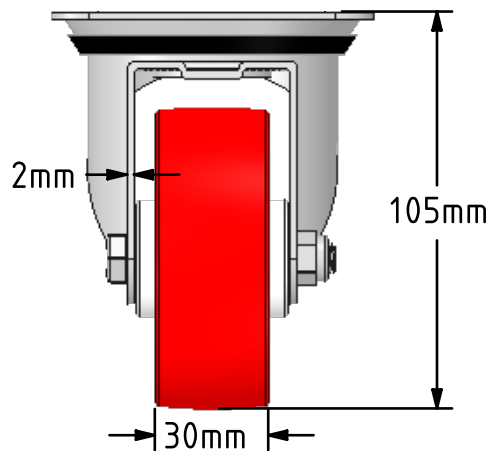
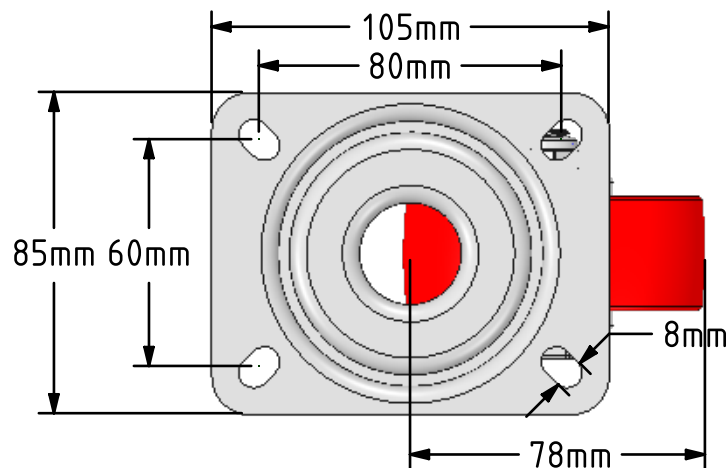

	NAME	DATE
DRAWN	Matt	05/07/18
APPROVED BY	Tim W	05/07/18
SCALE	1:2	05/07/18
WEIGHT	0.57kg	05/07/18

UNLESS OTHERWISE SPECIFIED DIMENSIONS ARE IN MILLIMETRES

Unspecified Tolerances  
 Machining ± 0.25mm  
 Fabrication ± 1mm



BIL Group Ltd, Porte Marsh Road, Calne  
 Wiltshire, SN11 9BW, United Kingdom  
 Tel +44 (0)1249 822 222 Fax: +44 (0)1249 822 300  
 www.bilgroup.co.uk

TITLE

SSMM80NPB

SIZE DWG NO.  
 A4 BILCW03SSMM80NPB\_02

REV  
 2

FILE NAME BILCW03SSMM80NPB\_02.PDF SHEET 1 OF 1