

DRAWING DISCLAIMER
 COPYRIGHT OF THIS DRAWING IS RESERVED BY BIL GROUP LTD. IT IS ISSUED ON CONDITION THAT IT IS NOT REPRODUCED, COPIED, OR DISCLOSED TO A THIRD PARTY EITHER WHOLLY OR IN PART WITHOUT THE CONSENT IN WRITING OF BIL GROUP LTD.

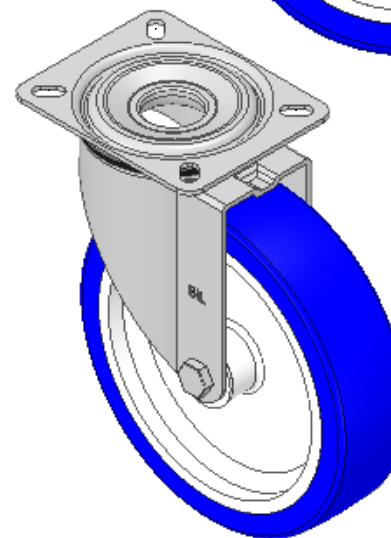

Description:
 SSMM200ENP

Grade 304 Pressed stainless steel swivel castor with a top plate fitted with a 82 shore A blue polyurethane tyre on white nylon centred wheel with plain bore, 200mm wheel diameter, 50mm tread width, 235mm overall height, 135 x 110mm top plate, 105 x 80mm bolt holes, with a load capacity of 400kgs.

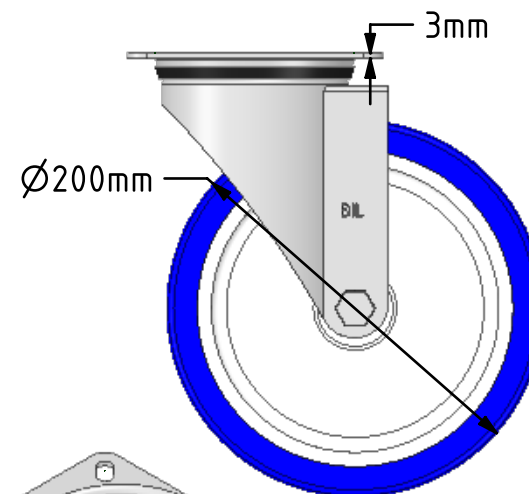
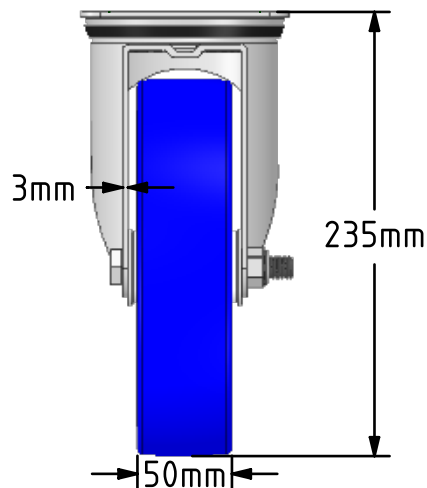
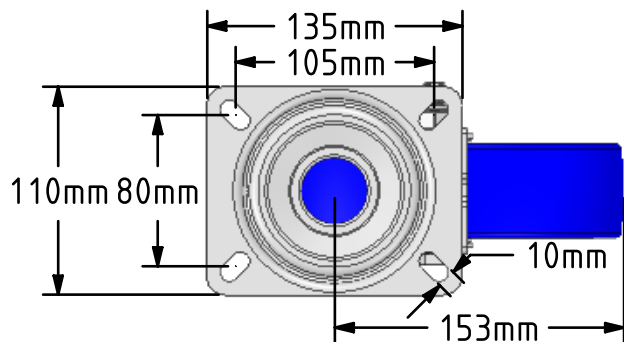

	NAME	DATE
DRAWN	Matt	06/03/19
APPROVED BY	Tim W	06/03/19
SCALE	1:4	06/03/19
WEIGHT	2.379kg	06/03/19

 BIL Group Ltd, Porte Marsh Road, Calne
 Wiltshire, SN11 9BW, United Kingdom
 Tel +44 (0)1249 822 222 Fax: +44 (0)1249 822 300
 www.bilgroup.co.uk

TITLE	
SSMM200ENP	

UNLESS OTHERWISE SPECIFIED DIMENSIONS ARE IN MILLIMETRES
 Unspecified Tolerances
 Machining ± 0.25mm
 Fabrication ± 1mm

SIZE	DWG NO.	REV
A4	BILCW03SSMM200ENP_02	2
FILE NAME	BILCW03SSMM200ENP_02.PDF SHEET 1 OF 1	