

DRAWING DISCLAIMER
 COPYRIGHT OF THIS DRAWING IS RESERVED BY BIL GROUP LTD. IT IS ISSUED ON CONDITION THAT IT IS NOT REPRODUCED, COPIED, OR DISCLOSED TO A THIRD PARTY EITHER WHOLLY OR IN PART WITHOUT THE CONSENT IN WRITING OF BIL GROUP LTD.

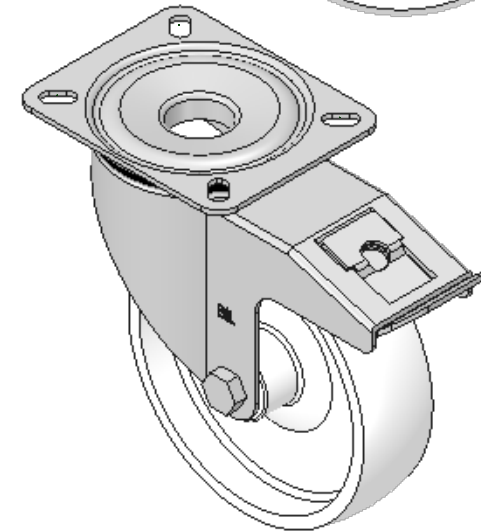

Description:
 SSMM160NYSWB

Grade 304 Pressed stainless steel swivel braked castor with a top plate fixing fitted with a white nylon wheel with a plain bearing. Wheel diameter 160mm, tread width 45mm overall height 195mm, top plate 135mm x 110mm, hole centres 105mm x 80mm. Load capacity 350kg.

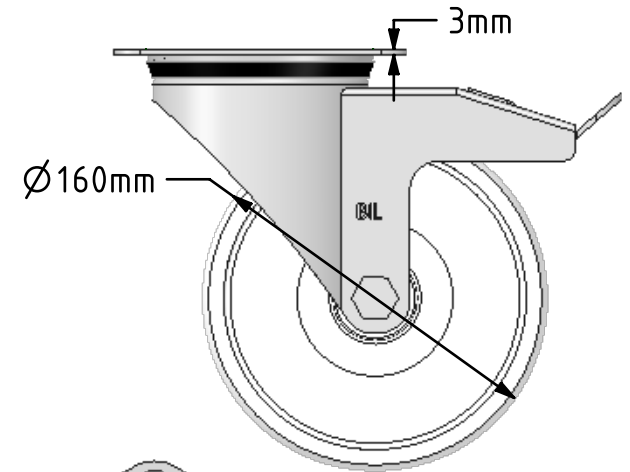
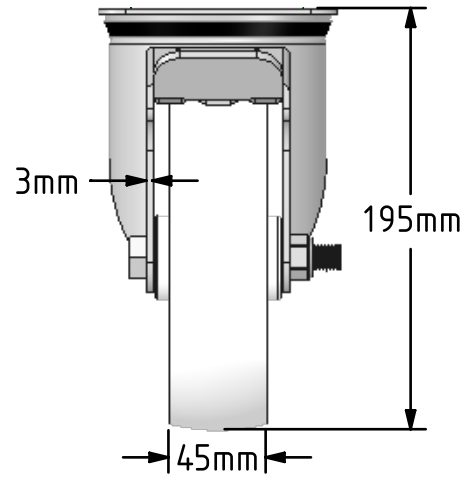
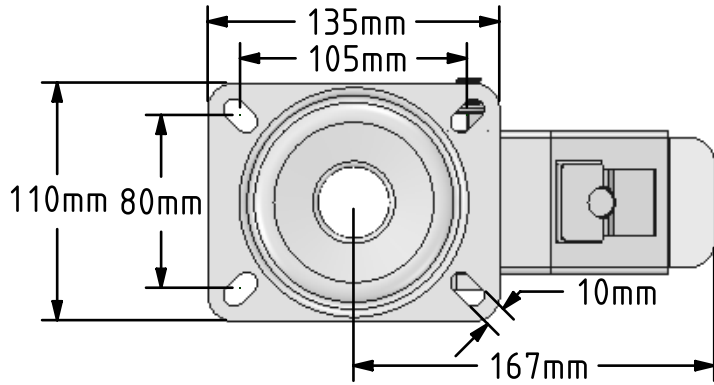

	NAME	DATE
DRAWN	Matt	24/07/18
APPROVED BY	Tim W	24/07/18
SCALE	2:7	24/07/18
WEIGHT	2.044kg	24/07/18

BIL BIL Group Ltd, Porte Marsh Road, Calne
 Wiltshire, SN11 9BW, United Kingdom
 Tel +44 (0)1249 822 222 Fax: +44 (0)1249 822 300
 www.bilgroup.co.uk

TITLE	
SSMM160NYSWB	

UNLESS OTHERWISE SPECIFIED DIMENSIONS ARE IN MILLIMETRES
 Unspecified Tolerances
 Machining ± 0.25mm
 Fabrication ± 1mm

SIZE	DWG NO.	REV
A4	BILCW03SSMM160NYSWB_01	1
FILE NAME	BILCW03SSMM160NYSWB_01.PDF SHEET 1 OF 1	