

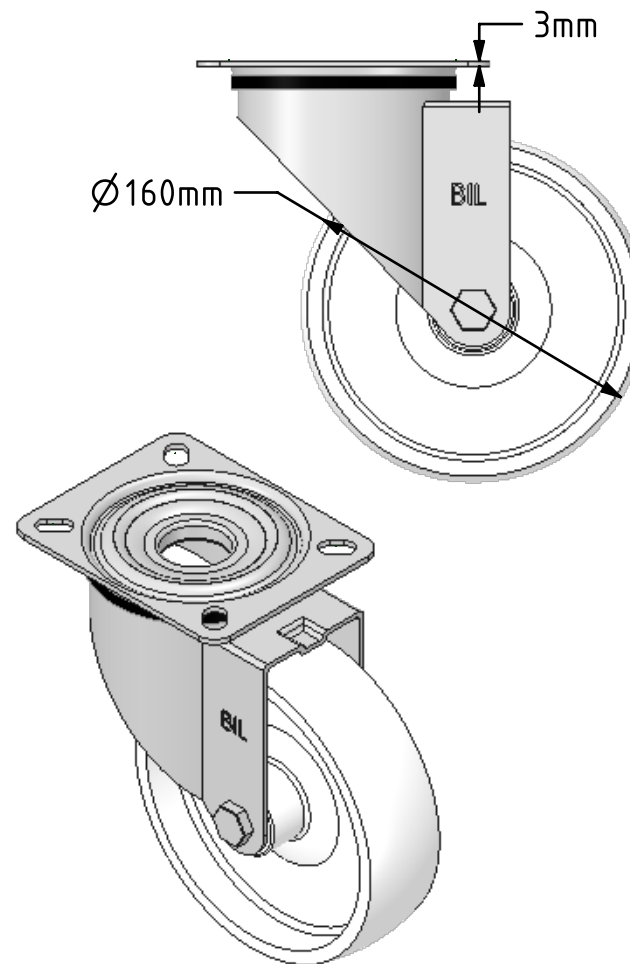

DRAWING DISCLAIMER  
 COPYRIGHT OF THIS DRAWING IS RESERVED BY BIL GROUP LTD. IT IS ISSUED ON CONDITION THAT IT IS NOT REPRODUCED, COPIED, OR DISCLOSED TO A THIRD PARTY EITHER WHOLLY OR IN PART WITHOUT THE CONSENT IN WRITING OF BIL GROUP LTD.

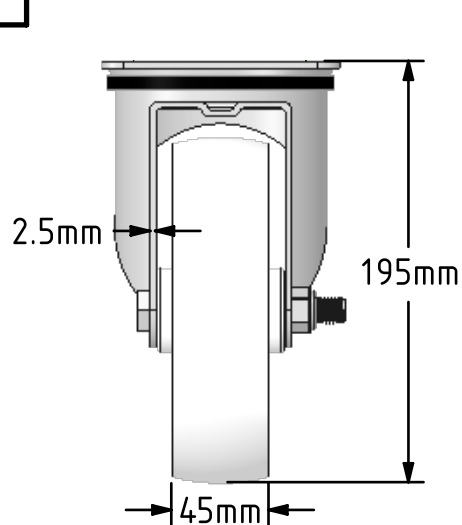
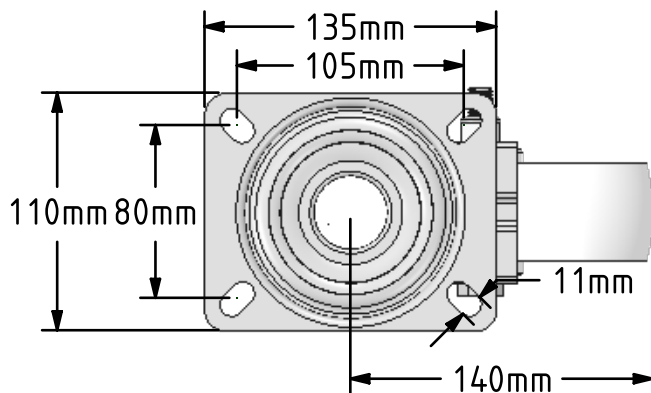

Description:  
 SSMM160NY

Grade 304 Pressed stainless steel swivel castor with a top plate fixing fitted with a white nylon wheel with a plain bearing. Wheel diameter 160mm, tread width 45mm, overall height 195mm, top plate 135mm x 105mm, hole centres 105mm x 80mm. Load capacity 350kg.



	NAME	DATE	 BIL Group Ltd, Porte Marsh Road, Calne Wiltshire, SN11 9BW, United Kingdom Tel +44 (0)1249 822 222 Fax: +44 (0)1249 822 300 www.bilgroup.co.uk	
DRAWN	Matt	18/07/18	TITLE	
APPROVED BY	Tim W	18/07/18	SSMM160NY	
SCALE	2:7	18/07/18	SIZE	DWG NO.
WEIGHT	1.615kg	18/07/18	A4	BILCW03SSMM160NY_01
UNLESS OTHERWISE SPECIFIED DIMENSIONS ARE IN MILLIMETRES			REV	1
Unspecified Tolerances Machining ± 0.25mm Fabrication ± 1mm			FILE NAME	BILCW03SSMM160NY_01.PDF SHEET 1 OF 1