

**DRAWING DISCLAIMER**  
 COPYRIGHT OF THIS DRAWING IS RESERVED BY BIL GROUP LTD. IT IS ISSUED ON CONDITION THAT IT IS NOT REPRODUCED, COPIED, OR DISCLOSED TO A THIRD PARTY EITHER WHOLLY OR IN PART WITHOUT THE CONSENT IN WRITING OF BIL GROUP LTD.

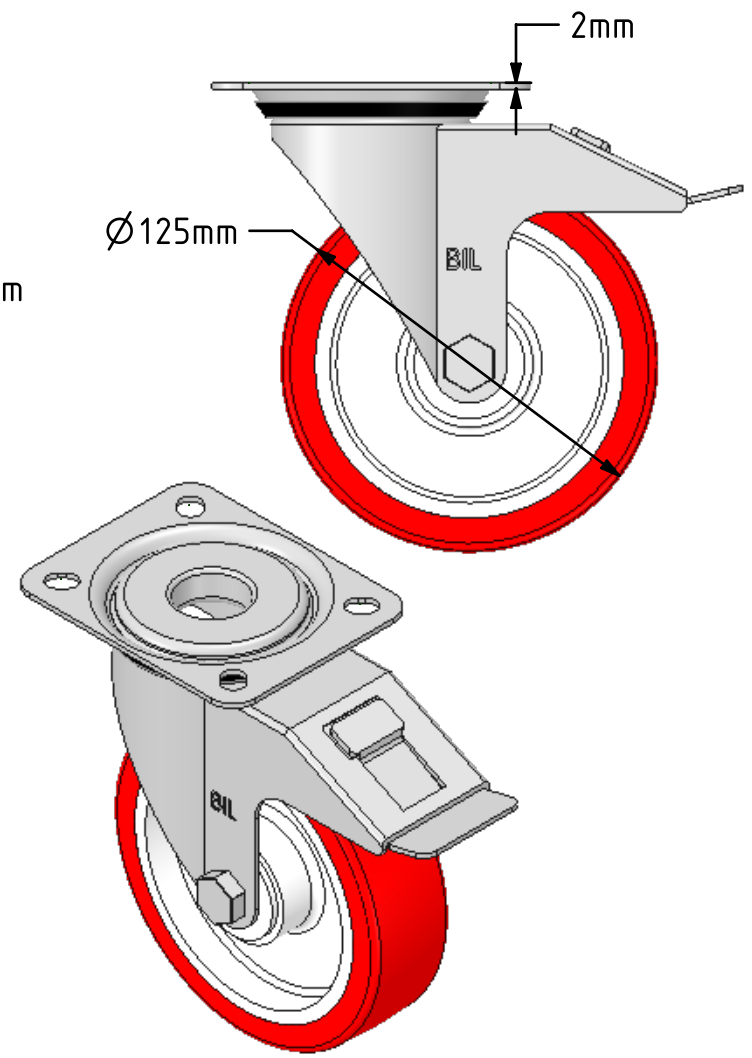

**Description:**  
 SSMM125NPBSWB

Grade 304 Pressed steel swivel castor with top plate fixing fitted with a red polyurethane tyre on white nylon centre wheel with a roller bearing and total lock brake. Wheel diameter 125mm, tread width 35mm, overall height 155mm, top plate 105mm x 85mm, hole centres 80mm x 60mm. Load capacity 200kg.

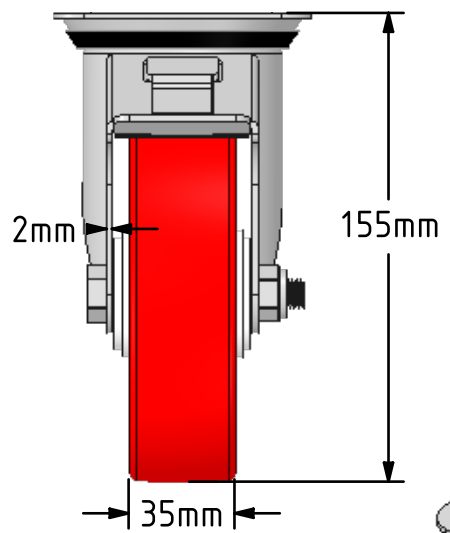
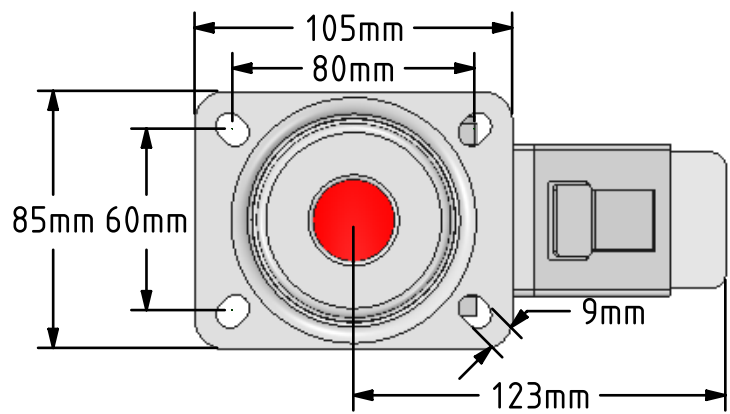

	NAME	DATE
DRAWN	Matt	24/07/18
APPROVED BY	Tim W	24/07/18
SCALE	2:5	24/07/18
WEIGHT	1.062kg	24/07/18

**BIL** Group Ltd, Porte Marsh Road, Calne  
 Wiltshire, SN11 9BW, United Kingdom  
 Tel +44 (0)1249 822 222 Fax: +44 (0)1249 822 300  
 www.bilgroup.co.uk

TITLE  
**SSMM125NPBSWB**

UNLESS OTHERWISE SPECIFIED DIMENSIONS ARE IN MILLIMETRES

Unspecified Tolerances  
 Machining ± 0.25mm  
 Fabrication ± 1mm

SIZE	DWG NO.	REV
A4	BILCW03SSMM125NPBSWB_01	1
FILE NAME BILCW03SSMM125NPBSWB_01.PDF		SHEET 1 OF 1