

DRAWING DISCLAIMER
 COPYRIGHT OF THIS DRAWING IS RESERVED BY BIL GROUP LTD. IT IS ISSUED ON CONDITION THAT IT IS NOT REPRODUCED, COPIED, OR DISCLOSED TO A THIRD PARTY EITHER WHOLLY OR IN PART WITHOUT THE CONSENT IN WRITING OF BIL GROUP LTD.

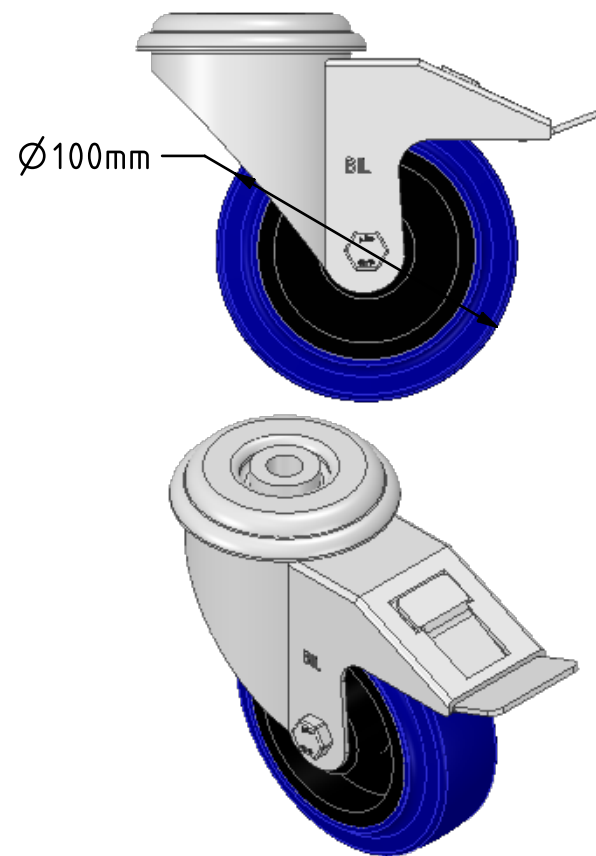

Description:
 SSMM100RNBBH12SWB

Grade 304 Pressed stainless steel swivel castor with a 12mm bolt hole fixing fitted with a blue 75 shore A elastic rubber tyre on black nylon centred wheel with a roller bearing and swivel wheel brake. Wheel diameter 100mm, tread width 36mm, overall height 128mm. Load capacity 160kg.

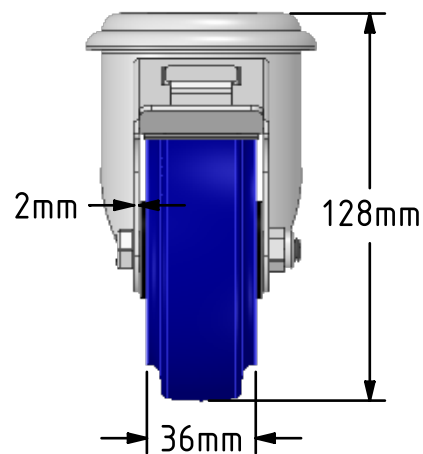
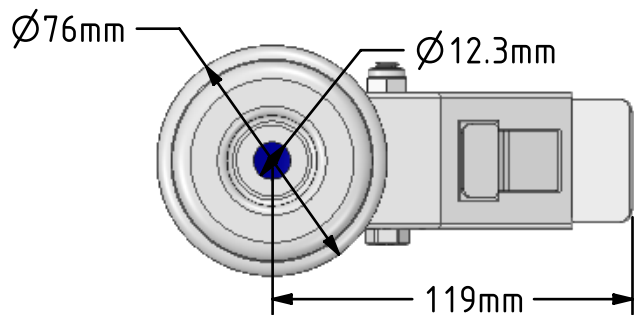

| | NAME | DATE |
|-------------|---------|----------|
| DRAWN | Matt | 20/03/19 |
| APPROVED BY | Tim W | 20/03/19 |
| SCALE | 2:5 | 20/03/19 |
| WEIGHT | 0.827kg | 20/03/19 |

UNLESS OTHERWISE SPECIFIED DIMENSIONS ARE IN MILLIMETRES

Unspecified Tolerances
 Machining ± 0.25mm
 Fabrication ± 1mm



BIL Group Ltd, Porte Marsh Road, Calne
 Wiltshire, SN11 9BW, United Kingdom
 Tel +44 (0)1249 822 222 Fax: +44 (0)1249 822 300
 www.bilgroup.co.uk

TITLE

SSMM100RNBBH12SWB

| SIZE | DWG NO. | REV |
|------|-----------------------------|-----|
| A4 | BILCW03SSMM100RNBBH12SWB_03 | 3 |

FILE NAME BILCW03SSMM100RNBBH12SWB_03.PDF SHEET 1 OF 1