

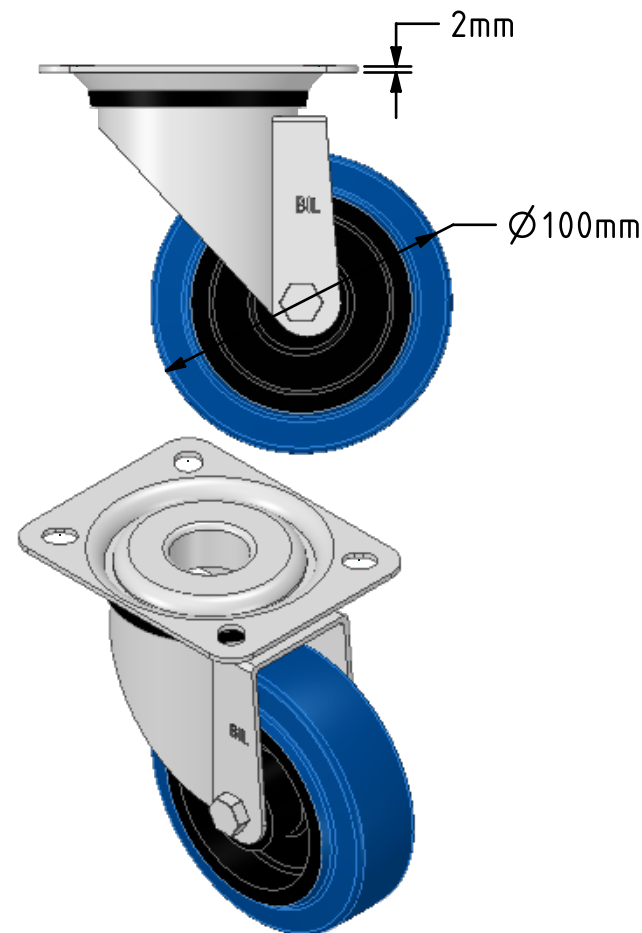

DRAWING DISCLAIMER
 COPYRIGHT OF THIS DRAWING IS RESERVED BY BIL GROUP LTD. IT IS ISSUED ON CONDITION THAT IT IS NOT REPRODUCED, COPIED, OR DISCLOSED TO A THIRD PARTY EITHER WHOLLY OR IN PART WITHOUT THE CONSENT IN WRITING OF BIL GROUP LTD.

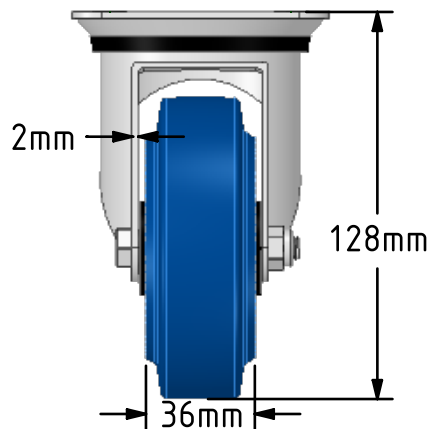
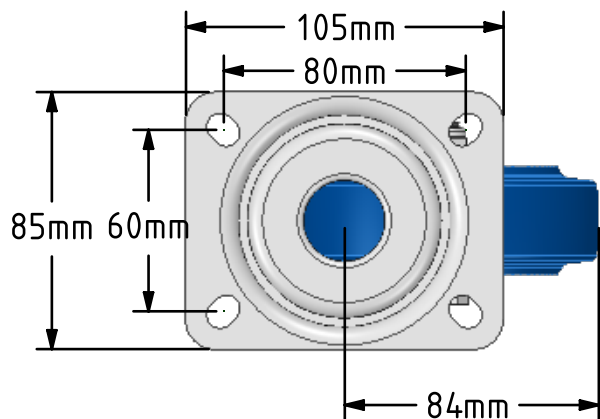
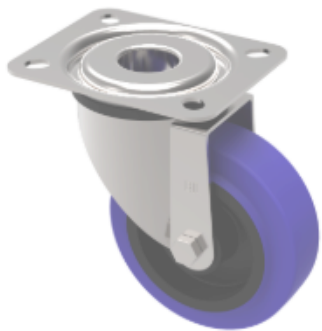

Description:
 SSMM100RN

Grade 304 Pressed stainless steel swivel castor with a top plate fixing fitted with a blue 75 shore A elastic rubber tyre on black nylon centred wheel with a plain bearing. Wheel diameter 100mm, tread width 36mm, overall height 128mm, top plate 105mm x 85mm, hole centres 80mm x 60mm. Load capacity 160kg.



	NAME	DATE	BIL Group Ltd, Porte Marsh Road, Calne Wiltshire, SN11 9BW, United Kingdom Tel +44 (0)1249 822 222 Fax: +44 (0)1249 822 300 www.bilgroup.co.uk		
DRAWN	Matt	20/03/19			
APPROVED BY	Chris	20/03/19			
SCALE	2:5	20/03/19			
WEIGHT	0.678kg	20/03/19			
UNLESS OTHERWISE SPECIFIED DIMENSIONS ARE IN MILLIMETRES			SIZE	DWG NO.	REV
Unspecified Tolerances Machining ± 0.25mm Fabrication ± 1mm			A4	BILCW03SSMM100RN_02	2
			FILE NAME	BILCW03SSMM100RN_02.PDF	SHEET 1 OF 1