

DRAWING DISCLAIMER
 COPYRIGHT OF THIS DRAWING IS RESERVED BY BIL GROUP LTD. IT IS ISSUED ON CONDITION THAT IT IS NOT REPRODUCED, COPIED, OR DISCLOSED TO A THIRD PARTY EITHER WHOLLY OR IN PART WITHOUT THE CONSENT IN WRITING OF BIL GROUP LTD.

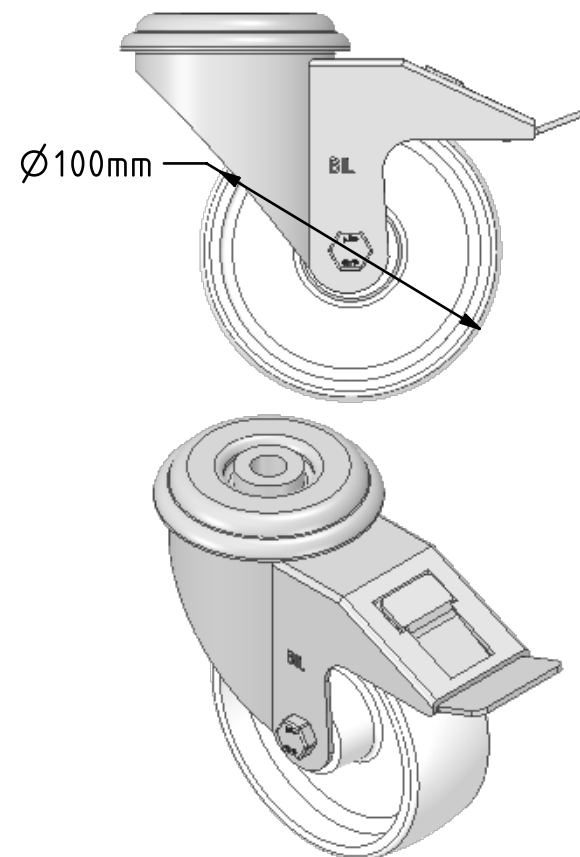

Description:
 SSMM100PLBH12SWB

Grade 304 Pressed stainless steel swivel castor with 12mm bolt hole fixing fitted with a white polypropylene wheel with plain bearing and swivel wheel brake. Wheel diameter 100mm, tread width 36mm, overall height 128mm. Load capacity 160kg.

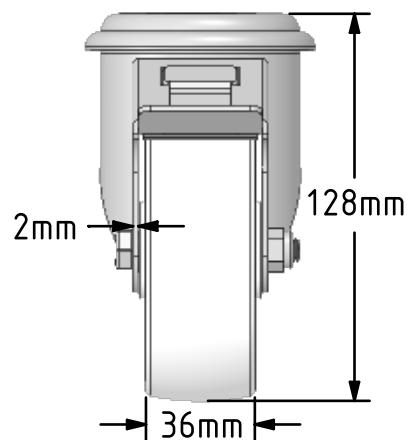
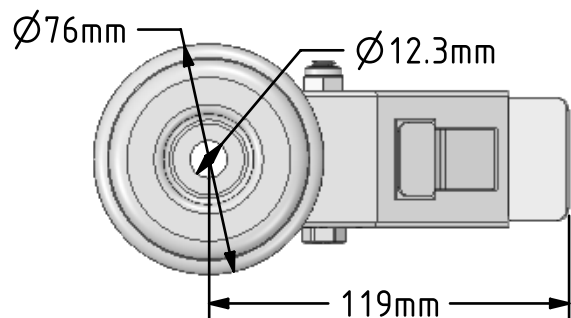

	NAME	DATE
DRAWN	Matt	20/03/19
APPROVED BY	Tim W	20/03/19
SCALE	2:5	20/03/19
WEIGHT	0.695kg	20/03/19

UNLESS OTHERWISE SPECIFIED DIMENSIONS ARE IN MILLIMETRES

Unspecified Tolerances
 Machining ± 0.25mm
 Fabrication ± 1mm



BIL Group Ltd, Porte Marsh Road, Calne
 Wiltshire, SN11 9BW, United Kingdom
 Tel +44 (0)1249 822 222 Fax: +44 (0)1249 822 300
 www.bilgroup.co.uk

TITLE

SSMM100PLBH12SWB

SIZE

DWG NO.

A4

BILCW03SSMM100PLBH12SWB_02

REV

2

FILE NAME BILCW03SSMM100PLBH12SWB_02.PDF SHEET 1 OF 1