

DRAWING DISCLAIMER  
 COPYRIGHT OF THIS DRAWING IS RESERVED BY BIL GROUP LTD. IT IS ISSUED ON CONDITION THAT IT IS NOT REPRODUCED, COPIED, OR DISCLOSED TO A THIRD PARTY EITHER WHOLLY OR IN PART WITHOUT THE CONSENT IN WRITING OF BIL GROUP LTD.

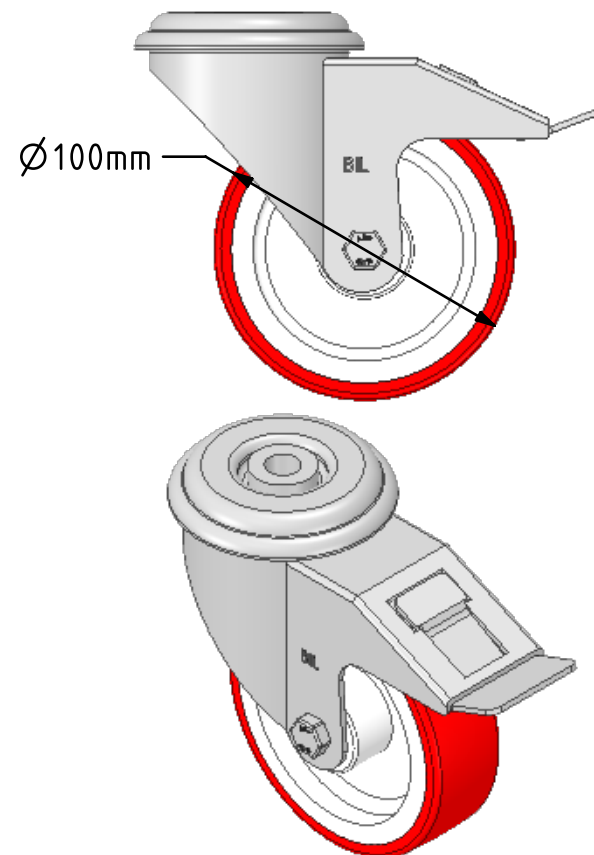

Description:  
 SSMM100NPBBH12SWB

Grade 304 Pressed stainless steel swivel castor with bolt hole fixing fitted with a polyurethane tyre nylon centred wheel with roller bearing and swivel wheel brake. Wheel diameter 100mm, tread width 30mm, overall height 128mm, 12mm bolt hole. Load capacity 180kg.

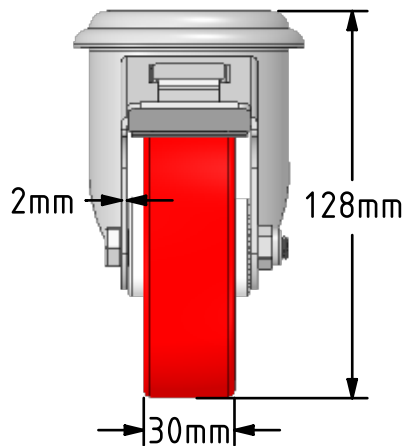
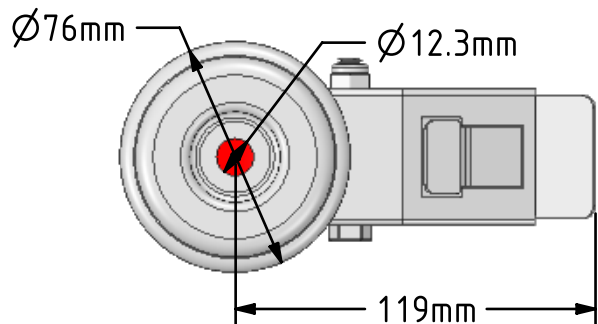

	NAME	DATE
DRAWN	Matt	20/03/19
APPROVED BY	Chris	20/03/19
SCALE	2:5	20/03/19
WEIGHT	0.789kg	20/03/19

UNLESS OTHERWISE SPECIFIED DIMENSIONS ARE IN MILLIMETRES

Unspecified Tolerances  
 Machining ± 0.25mm  
 Fabrication ± 1mm



BIL Group Ltd, Porte Marsh Road, Calne  
 Wiltshire, SN11 9BW, United Kingdom  
 Tel +44 (0)1249 822 222 Fax: +44 (0)1249 822 300  
 www.bilgroup.co.uk

TITLE

SSMM100NPBBH12SWB

SIZE	DWG NO.	REV
A4	BILCW03SSMM100NPBBH12SWB__02	2

FILE NAME BILCW03SSMM100NPBBH12SWB\_\_02.PDF SHEET 1 OF 1