

DRAWING DISCLAIMER
 COPYRIGHT OF THIS DRAWING IS RESERVED BY BIL GROUP LTD. IT IS ISSUED ON CONDITION THAT IT IS NOT REPRODUCED, COPIED, OR DISCLOSED TO A THIRD PARTY EITHER WHOLLY OR IN PART WITHOUT THE CONSENT IN WRITING OF BIL GROUP LTD.

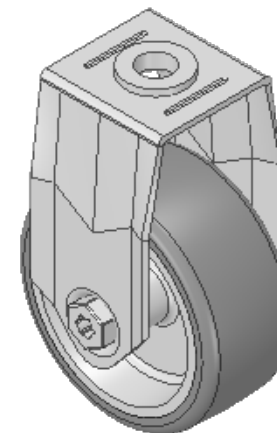

Description:
 SSMF75VGRBH12

Pressed stainless steel fixed castor with a 12mm bolt hole fitted with a grey thermoplastic rubber tyre on polypropylene centred wheel with plain bearing. Wheel diameter 75mm, tread width 32mm, overall height 109mm, Load capacity 70kg.

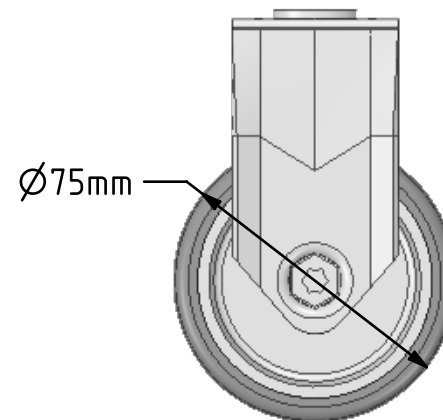
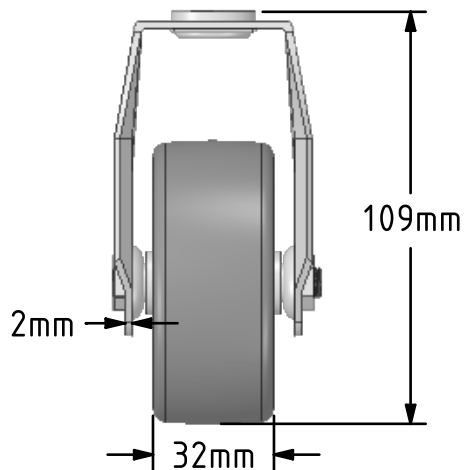
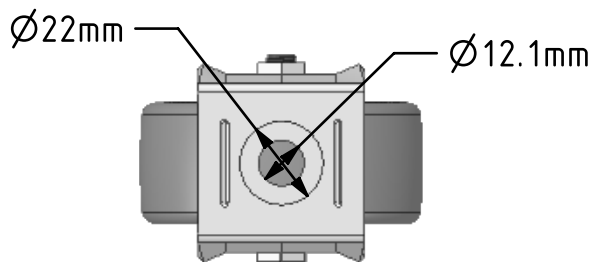

	NAME	DATE
DRAWN	Matt	29/11/18
APPROVED BY	Tim W	29/11/18
SCALE	1:2	29/11/18
WEIGHT	0.285kg	29/11/18

 BIL Group Ltd, Porte Marsh Road, Calne
 Wiltshire, SN11 9BW, United Kingdom
 Tel +44 (0)1249 822 222 Fax: +44 (0)1249 822 300
 www.bilgroup.co.uk

TITLE
SSMF75VGRBH12

UNLESS OTHERWISE SPECIFIED DIMENSIONS ARE IN MILLIMETRES
 Unspecified Tolerances
 Machining ± 0.25mm
 Fabrication ± 1mm

SIZE	DWG NO.	REV
A4	BILCW03SSMF75VGRBH12__01	1
FILE NAME	BILCW03SSMF75VGRBH12__01.PDF SHEET 1 OF 1	