

DRAWING DISCLAIMER
 COPYRIGHT OF THIS DRAWING IS RESERVED BY BIL GROUP LTD. IT IS ISSUED ON CONDITION THAT IT IS NOT REPRODUCED, COPIED, OR DISCLOSED TO A THIRD PARTY EITHER WHOLLY OR IN PART WITHOUT THE CONSENT IN WRITING OF BIL GROUP LTD.

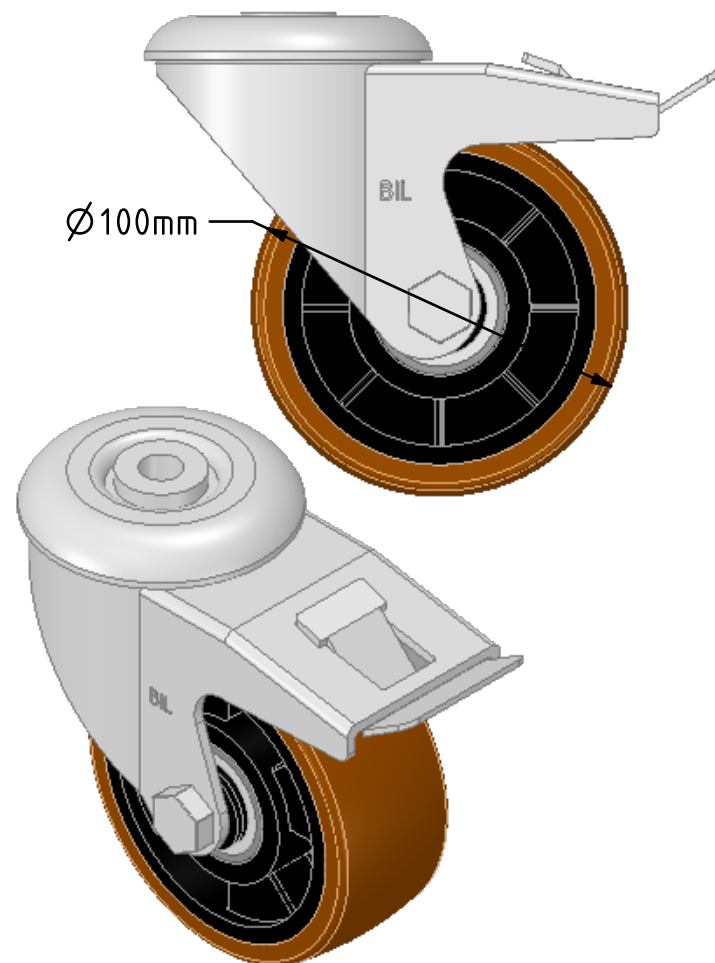

Description:
 SSEH100XPNBJBH12SWB

Stainless Pressed steel swivel castor with a bolt hole fixing fitted with a brown polyurethane tyre on black nylon centred wheel with stainless ball bearings with total lock brake. Wheel diameter 100mm, tread width 40mm, overall height 128mm, bolt hole 12mm. Load capacity 300kg

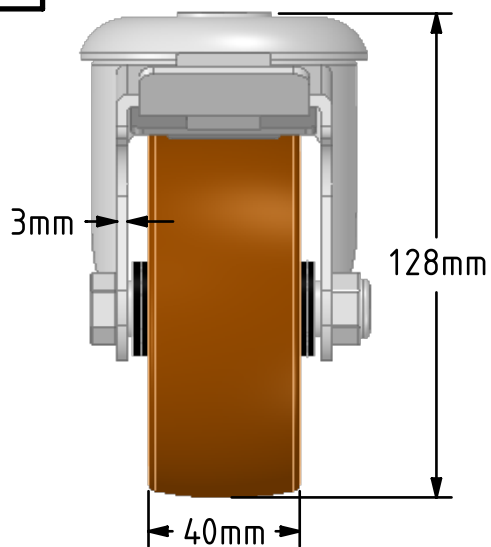
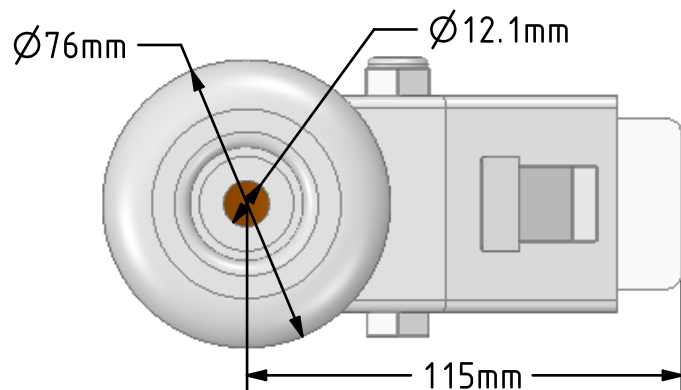

	NAME	DATE
DRAWN	Matt	23/10/18
APPROVED BY	Tim W	23/10/18
SCALE	1:2	23/10/18
WEIGHT	1.163kg	23/10/18

BIL BIL Group Ltd, Porte Marsh Road, Calne
 Wiltshire, SN11 9BW, United Kingdom
 Tel +44 (0)1249 822 222 Fax: +44 (0)1249 822 300
 www.bilgroup.co.uk

TITLE
SSEH100XPNBJBH12SWB

UNLESS OTHERWISE SPECIFIED DIMENSIONS ARE IN MILLIMETRES
 Unspecified Tolerances
 Machining ± 0.25mm
 Fabrication ± 1mm

SIZE	DWG NO.	REV
A4	BILC03SSEH100XPNBJBH12SWB_01	1
FILE NAME BILC03SSEH100XPNBJBH12SWB_01.PDF		SHEET 1 OF 1