

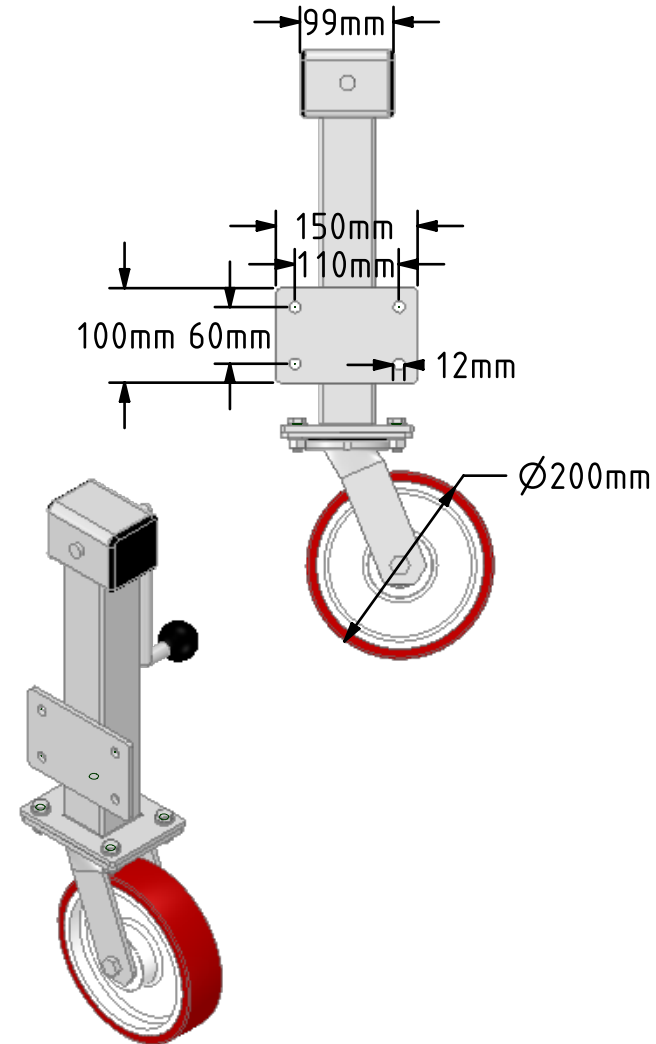

**DRAWING DISCLAIMER**  
 COPYRIGHT OF THIS DRAWING IS RESERVED BY BIL GROUP LTD. IT IS ISSUED ON CONDITION THAT IT IS NOT REPRODUCED, COPIED, OR DISCLOSED TO A THIRD PARTY EITHER WHOLLY OR IN PART WITHOUT THE CONSENT IN WRITING OF BIL GROUP LTD.

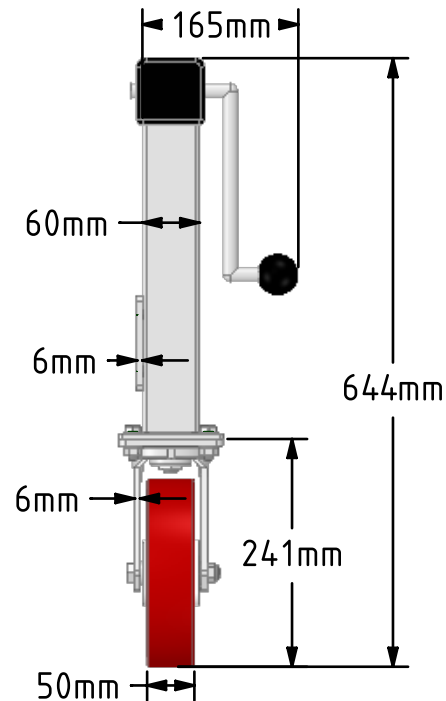

**Description:**  
 JAZHS200NPBJ  
 Side winding jacking unit with maximum lift of 200mm fitted with a fabricated swivel castor with a top plate fixing fitted with a red polyurethane tyre on a white nylon centred wheel with ball bearing. Wheel diameter 200mm, tread width 50mm, maximum load for the complete unit is capacity 500kg. Please note Jacking castors are rated on a different principal to other castors and we recommend the total lifted load is divided over just 2 jacking units. When jacked up to the height please be aware of any obstacles as a sudden shock could result in the inner square tube bending around the outer tube.

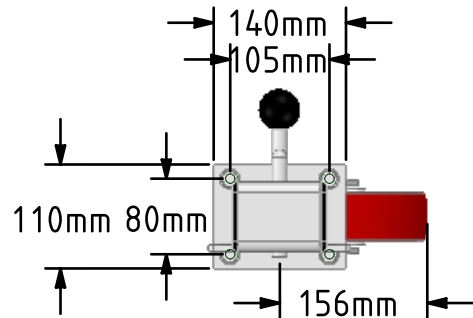

	NAME	DATE	 BIL Group Ltd, Porte Marsh Road, Calne Wiltshire, SN11 9BW, United Kingdom Tel +44 (0)1249 822 222 Fax: +44 (0)1249 822 300 www.bilgroup.co.uk
DRAWN	Matt	21/09/18	
APPROVED BY	Chris	21/09/18	
SCALE	1:8	21/09/18	
WEIGHT	10.774kg	21/09/18	
UNLESS OTHERWISE SPECIFIED DIMENSIONS ARE IN MILLIMETRES  Unspecified Tolerances Machining ± 0.25mm Fabrication ± 1mm			TITLE <b>JAZHS200NPBJ</b>
SIZE	DWG NO.		REV
A4	BILCW03JAZHS200NPBJ_01		1
FILE NAME BILCW03JAZHS200NPBJ_01.PDF			SHEET 1 OF 1