

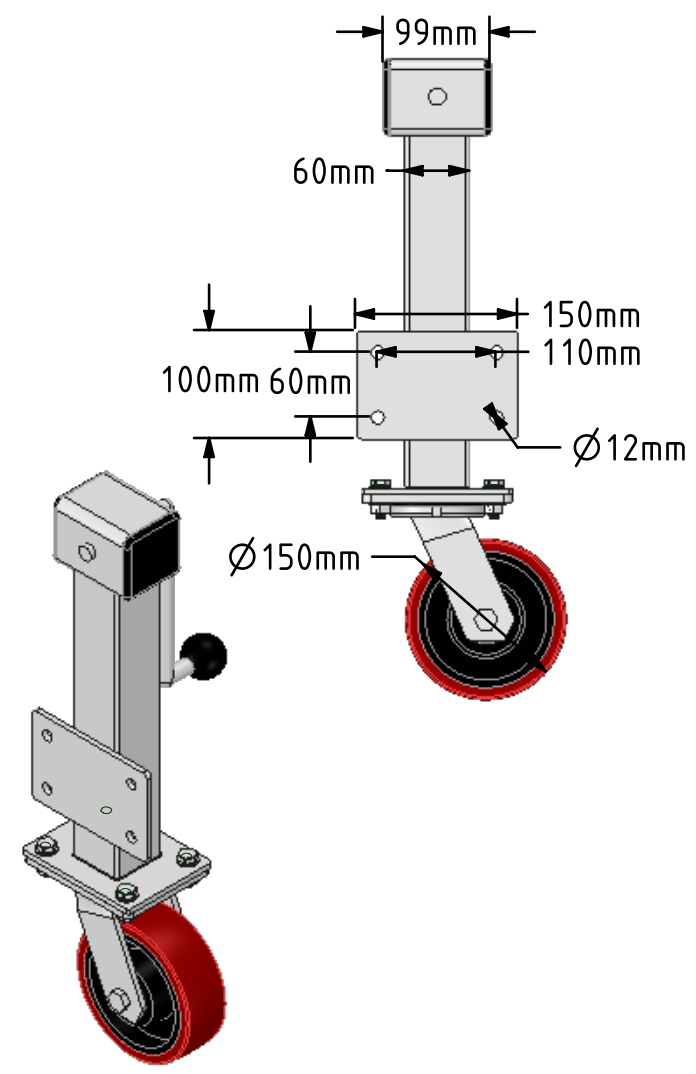

DRAWING DISCLAIMER
 COPYRIGHT OF THIS DRAWING IS RESERVED BY BIL GROUP LTD. IT IS ISSUED ON CONDITION THAT IT IS NOT REPRODUCED, COPIED, OR DISCLOSED TO A THIRD PARTY EITHER WHOLLY OR IN PART WITHOUT THE CONSENT IN WRITING OF BIL GROUP LTD.

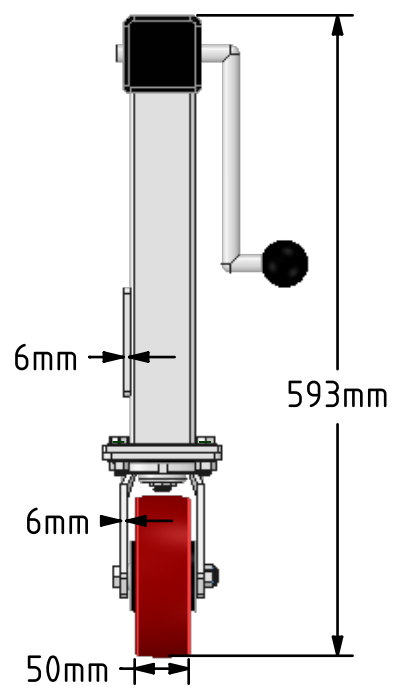

Description:
 JAZHS150PTBJ
 Side winding jacking unit with maximum lift of 200mm fitted with a Fabricated swivel castor with a top plate fixing fitted with a brown polyurethane tyred cast iron centred wheel with ball bearings. Wheel diameter 150mm, tread width 50mm, maximum Load for the complete unit is capacity 600kg. Please note Jacking castors are rated on a different principal to other castors and we recommend the total lifted load is divided over just 2 jacking units. When jacked up to the height please be aware of any obstacles as a sudden shock could result in the inner square tube bending around the outer tube.

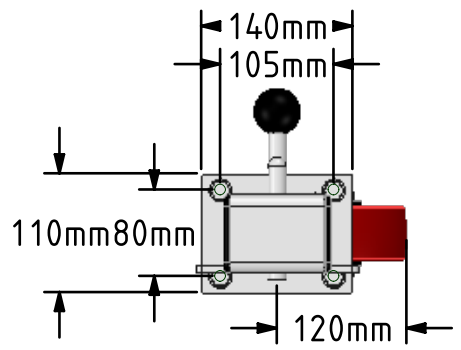

	NAME	DATE	 BIL Group Ltd, Porte Marsh Road, Calne Wiltshire, SN11 9BW, United Kingdom Tel +44 (0)1249 822 222 Fax: +44 (0)1249 822 300 www.bilgroup.co.uk
DRAWN	Matt	08/06/18	
APPROVED BY	Chris	08/06/18	
SCALE	1:7	08/06/18	
WEIGHT	11.893kg	08/06/18	
UNLESS OTHERWISE SPECIFIED DIMENSIONS ARE IN MILLIMETRES Unspecified Tolerances Machining ± 0.25mm Fabrication ± 1mm			TITLE JAZHS150PTBJ
SIZE		DWG NO.	REV
A4		BILCW03JAZHS150PTBJ_01	1
FILE NAME			SHEET 1 OF 1
BILCW03JAZHS150PTBJ_01.PDF			