

DRAWING DISCLAIMER
 COPYRIGHT OF THIS DRAWING IS RESERVED BY BIL GROUP LTD. IT IS ISSUED ON CONDITION THAT IT IS NOT REPRODUCED, COPIED, OR DISCLOSED TO A THIRD PARTY EITHER WHOLLY OR IN PART WITHOUT THE CONSENT IN WRITING OF BIL GROUP LTD.

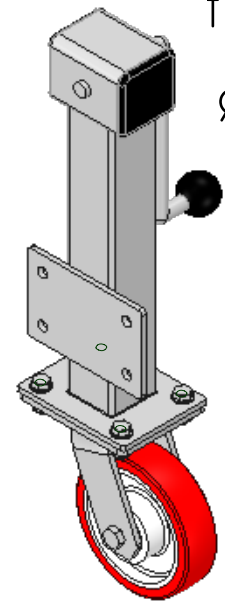

Description:
 JAZHS150NPBJ
 Side winding jacking unit with maximum lift of 200mm fitted with a Fabricated swivel castor with a top plate fixing fitted with a red polyurethane tyre on a white nylon centred wheel with ball bearing bore. Wheel diameter 150mm, tread width 40mm, maximum Load for the complete unit is capacity 500kg. Please note Jacking castors are rated on a different principal to other castors and we recommend the total lifted load is divided over just 2 jacking units. When jacked up to the height please be aware of any obstacles as a sudden shock could result in the inner square tube bending around the outer tube.

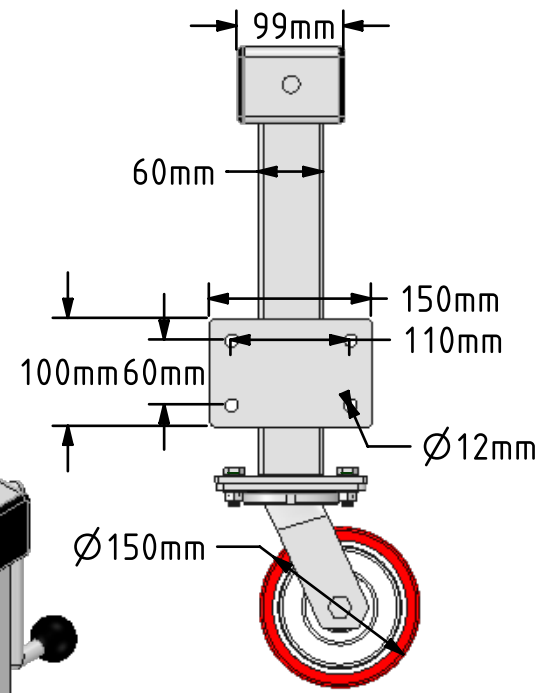
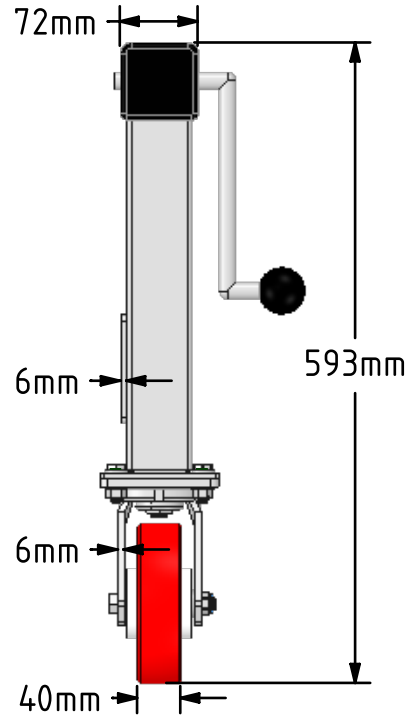
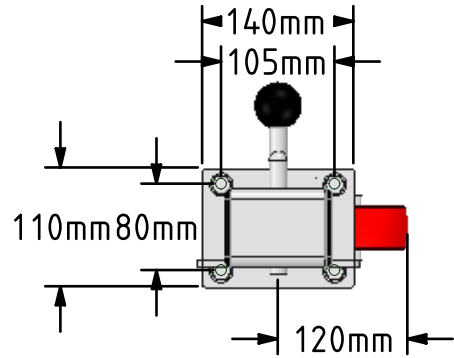

	NAME	DATE
DRAWN	Matt	08/06/18
APPROVED BY	Chris	08/06/18
SCALE	1:7	08/06/18
WEIGHT	10.175kg	08/06/18

BIL BIL Group Ltd, Porte Marsh Road, Calne Wiltshire, SN11 9BW, United Kingdom
 Tel +44 (0)1249 822 222 Fax: +44 (0)1249 822 300
 www.bilgroup.co.uk

TITLE
JAZHS150NPBJ

UNLESS OTHERWISE SPECIFIED DIMENSIONS ARE IN MILLIMETRES
 Unspecified Tolerances
 Machining ± 0.25mm
 Fabrication ± 1mm

SIZE	DWG NO.	REV
A4	BILCW03JAZHS150NPBJ_01	1
FILE NAME	BILCW03JAZHS150NPBJ_01.PDF SHEET 1 OF 1	