

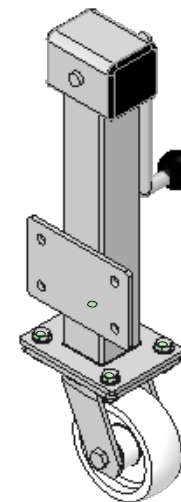

**DRAWING DISCLAIMER**  
 COPYRIGHT OF THIS DRAWING IS RESERVED BY BIL GROUP LTD. IT IS ISSUED ON CONDITION THAT IT IS NOT REPRODUCED, COPIED, OR DISCLOSED TO A THIRD PARTY EITHER WHOLLY OR IN PART WITHOUT THE CONSENT IN WRITING OF BIL GROUP LTD.

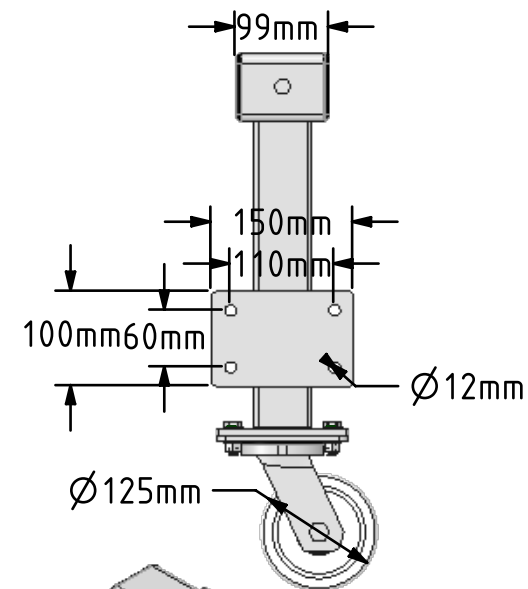

**Description:**  
 JAZHS125NY  
 Side winding jacking unit with maximum lift of 200mm fitted with a Fabricated swivel castor with a top plate fixing fitted with a white nylon wheel with plain bore. Wheel diameter 125mm, tread width 45mm, maximum Load for the complete unit is capacity 600kg. Please note Jacking castors are rated on a different principal to other castors and we recommend the total lifted load is divided over just 2 jacking units. When jacked up to the height please beware of any obstacles as a sudden shock could result in the inner square tube bending around the outer tube.

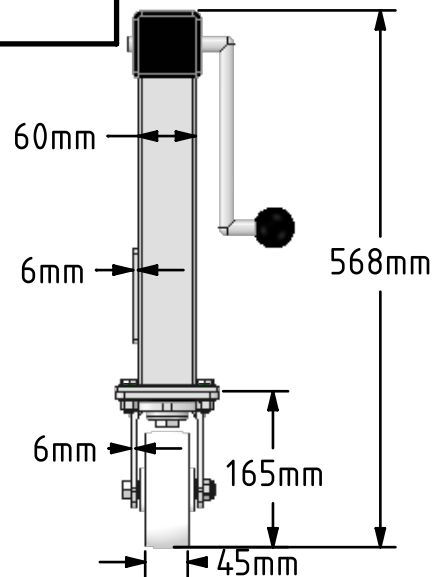
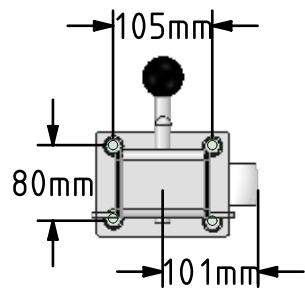

	NAME	DATE	 BIL Group Ltd, Porte Marsh Road, Calne Wiltshire, SN11 9BW, United Kingdom Tel +44 (0)1249 822 222 Fax: +44 (0)1249 822 300 www.bilgroup.co.uk	
DRAWN	Matt	20/03/18	TITLE	
APPROVED BY	Chris	20/03/18	JAZHS125NY	
SCALE	1:8	20/03/18	SIZE	DWG NO.
WEIGHT	9.779kg	20/03/18	A4	BILCW03JAZHS125NY_01
UNLESS OTHERWISE SPECIFIED DIMENSIONS ARE IN MILLIMETRES Unspecified Tolerances Machining ± 0.25mm Fabrication ± 1mm			REV	1
			FILE NAME	BILCW03JAZHS125NY_01.PDF SHEET 1 OF 1