

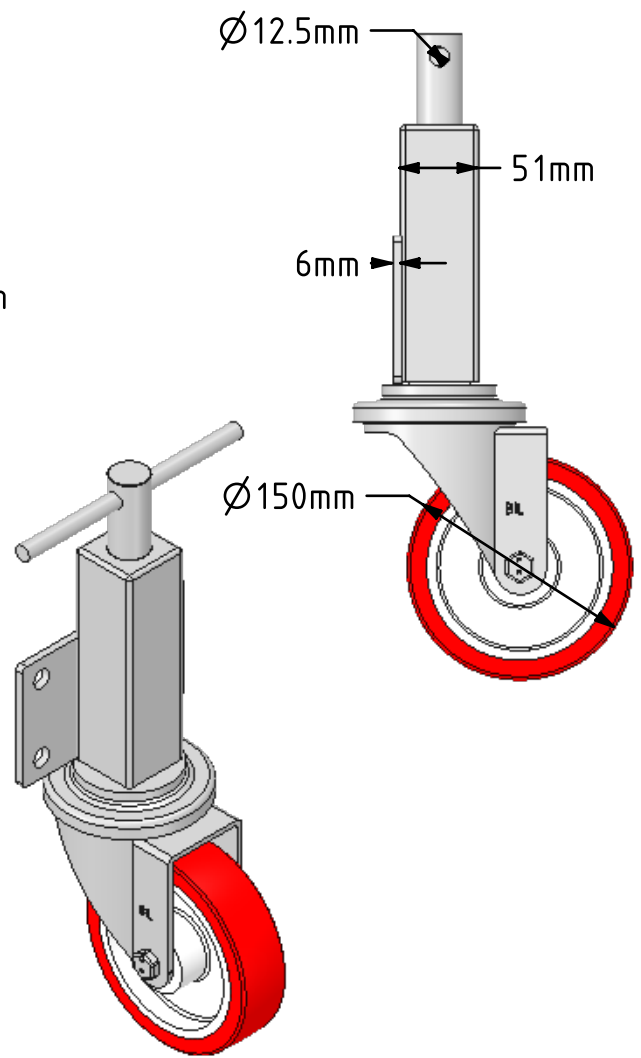

DRAWING DISCLAIMER
 COPYRIGHT OF THIS DRAWING IS RESERVED BY BIL GROUP LTD. IT IS ISSUED ON CONDITION THAT IT IS NOT REPRODUCED, COPIED, OR DISCLOSED TO A THIRD PARTY EITHER WHOLLY OR IN PART WITHOUT THE CONSENT IN WRITING OF BIL GROUP LTD.

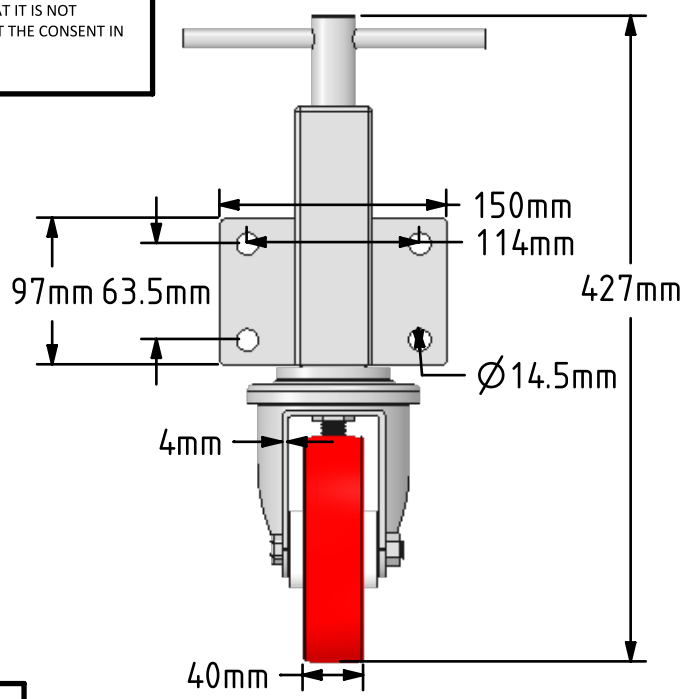

Description:
 JAZ150NPB
 Zinc plated box jacking unit with side fitting plate and a 75mm lift fitted with a 150mm white zinc plated swivel pressed steel castor with a red polyurethane tyred white nylon centred wheel with roller bearing bore with a load capacity of 250kg Please note Jacking castors are rated on a different principal to other castors and we recommend the total lifted load is divided over just 2 jacking units. 1 extra safety point is when jacked up please beware of any obstacles as a sudden shock could result in the inner square tube bending around the outer tube.

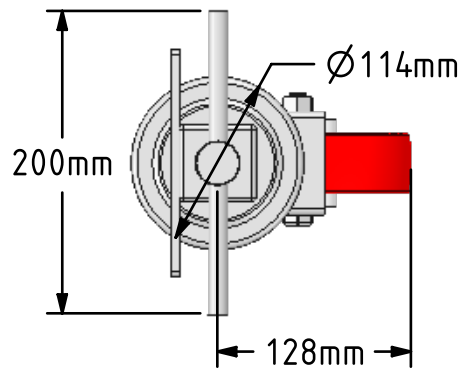

	NAME	DATE	 BIL Group Ltd, Porte Marsh Road, Calne Wiltshire, SN11 9BW, United Kingdom Tel +44 (0)1249 822 222 Fax: +44 (0)1249 822 300 www.bilgroup.co.uk
DRAWN	Matt	07/06/18	
APPROVED BY	Tim W	07/06/18	
SCALE	1:5	07/06/18	
WEIGHT	5.65kg	07/06/18	TITLE
UNLESS OTHERWISE SPECIFIED DIMENSIONS ARE IN MILLIMETRES Unspecified Tolerances Machining ± 0.25mm Fabrication ± 1mm			JAZ150NPB
SIZE		DWG NO.	REV
A4		BILCW03JAZ150NPB_01	1
FILE NAME		BILCW03JAZ150NPB_01.PDF	SHEET 1 OF 1