

DRAWING DISCLAIMER
 COPYRIGHT OF THIS DRAWING IS RESERVED BY BIL GROUP LTD. IT IS ISSUED ON CONDITION THAT IT IS NOT REPRODUCED, COPIED, OR DISCLOSED TO A THIRD PARTY EITHER WHOLLY OR IN PART WITHOUT THE CONSENT IN WRITING OF BIL GROUP LTD.

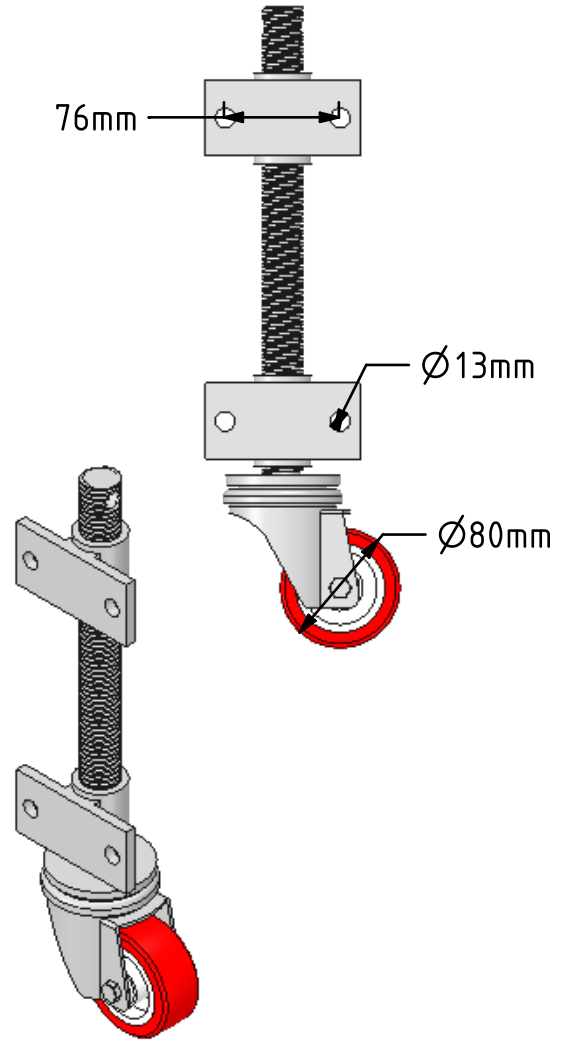

Description:
 JAB80NP
 Open screw thread jacking castor with side fitting nuts with 160mm lift fitted with a 80mm white zinc plated swivel pressed steel castor with a red polyurethane tyred white nylon centred wheel with a plain bore and a load capacity of 140kg Please note Jacking castors are rated on a different principal to other castors and we recommend the total lifted load is divided over just 2 jacking units.1 extra safety point is when jacked up please beware of any obstacles as a sudden shock could result in bending the thread but more likely the castor will tear away from the screw thread.

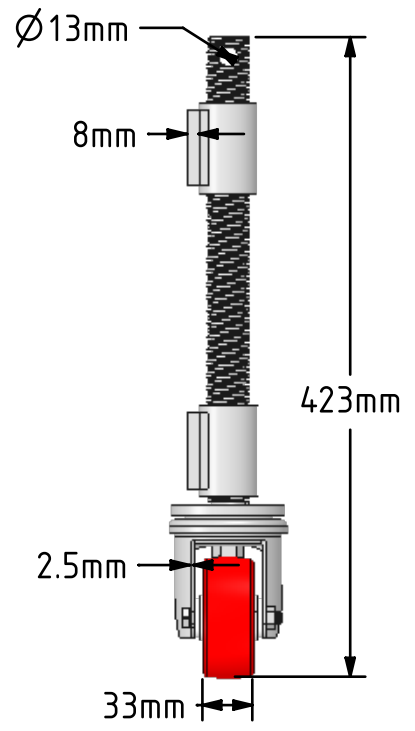
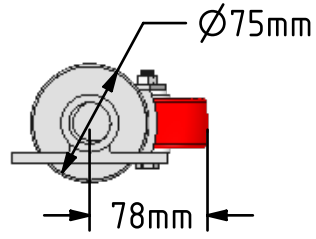

	NAME	DATE
DRAWN	Matt	01/09/17
APPROVED BY	Chris	01/09/17
SCALE	1:5	01/09/17
WEIGHT	3.248kg	01/09/17

UNLESS OTHERWISE SPECIFIED DIMENSIONS ARE IN MILLIMETRES
 Unspecified Tolerances
 Machining ± 0.25mm
 Fabrication ± 1mm

 BIL Group Ltd, Porte Marsh Road, Calne Wiltshire, SN11 9BW, United Kingdom Tel +44 (0)1249 822 222 Fax: +44 (0)1249 822 300 www.bilgroup.co.uk		TITLE	
		JAB80NP	
SIZE	DWG NO.	REV	
A4	BILCW03JAB80NP__01	1	
FILE NAME	BILCW03JAB80NP__01.PDF		SHEET 1 OF 1