

**DRAWING DISCLAIMER**  
 COPYRIGHT OF THIS DRAWING IS RESERVED BY BIL GROUP LTD. IT IS ISSUED ON CONDITION THAT IT IS NOT REPRODUCED, COPIED, OR DISCLOSED TO A THIRD PARTY EITHER WHOLLY OR IN PART WITHOUT THE CONSENT IN WRITING OF BIL GROUP LTD.

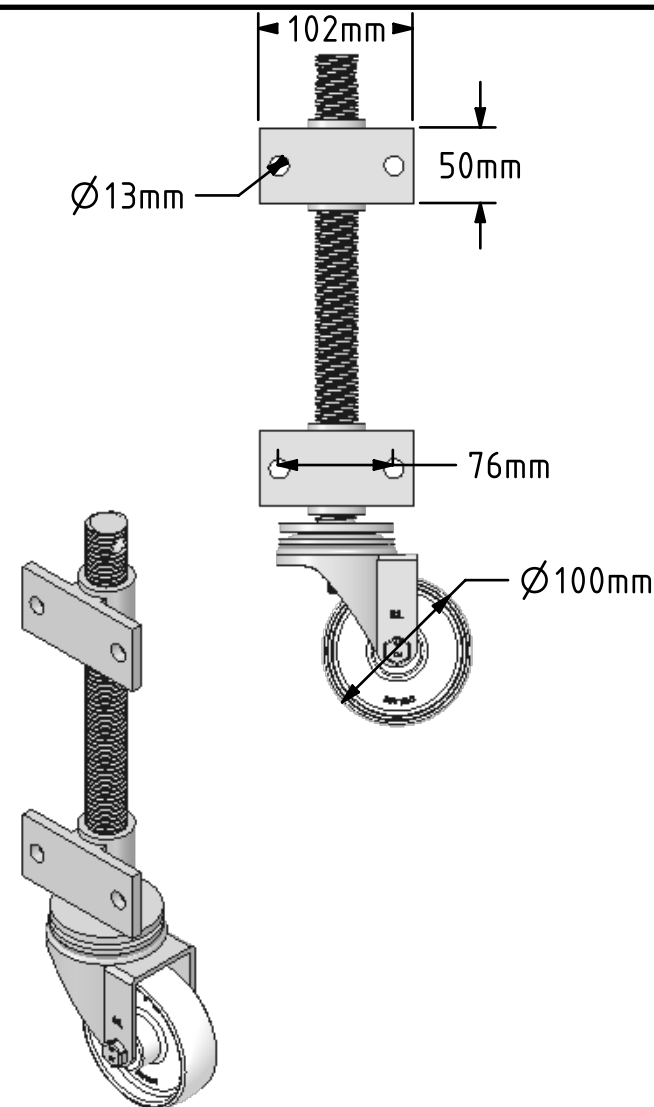

**Description:**  
 JAB100NYB

Open screw thread jacking castor with side fitting nuts with 160mm lift fitted with a 100mm white zinc plated swivel pressed steel castor with a white nylon wheel with a roller bearing with a load capacity of 140kg. Please note Jacking castors are rated on a different principal to other castors and we recommend the total lifted load is divided over just 2 jacking units. 1 extra safety point is when jacked up please beware of any obstacles as a sudden shock could result in bending the thread but more likely the castor will tear away from the screw thread.

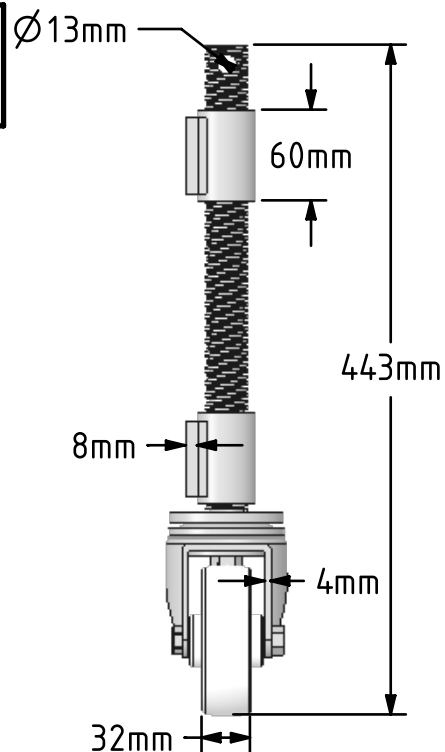
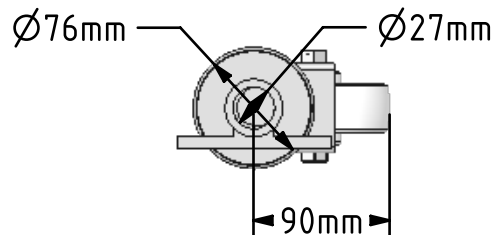

	NAME	DATE
DRAWN	Matt	05/06/18
APPROVED BY	Tim W	05/06/18
SCALE	1:5	05/06/18
WEIGHT	3.417kg	05/06/18

UNLESS OTHERWISE SPECIFIED DIMENSIONS ARE IN MILLIMETRES

Unspecified Tolerances  
 Machining ± 0.25mm  
 Fabrication ± 1mm



BIL Group Ltd, Porte Marsh Road, Calne  
 Wiltshire, SN11 9BW, United Kingdom  
 Tel +44 (0)1249 822 222 Fax: +44 (0)1249 822 300  
 www.bilgroup.co.uk

TITLE

JAB100NYB

SIZE A4  
 DWG NO.

BILCW03JAB100NYB\_01

REV 1

FILE NAME

BILCW03JAB100NYB\_01.PDF

SHEET 1 OF 1