

DRAWING DISCLAIMER
 COPYRIGHT OF THIS DRAWING IS RESERVED BY BIL GROUP LTD. IT IS ISSUED ON CONDITION THAT IT IS NOT REPRODUCED, COPIED, OR DISCLOSED TO A THIRD PARTY EITHER WHOLLY OR IN PART WITHOUT THE CONSENT IN WRITING OF BIL GROUP LTD.

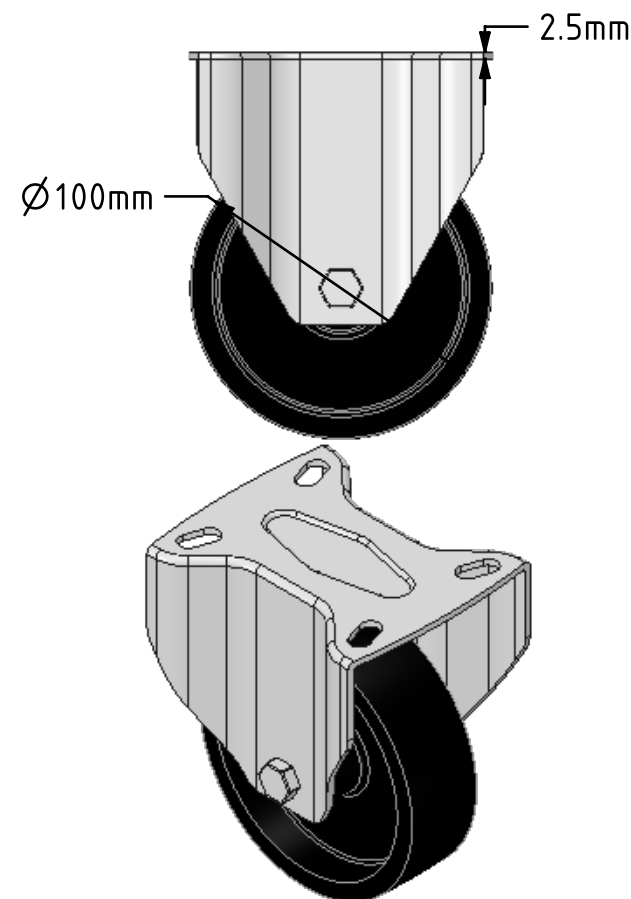

Description:
 BZXMF100TP3TF

Pressed steel fixed castor with a top plate fixing fitted with a 300oC black thermoplastic wheel with teflon bushes. Wheel diameter 100mm, tread width 30mm, overall height 128mm, top plate 105mm x 80mm, hole centres 80mm x 60mm or 75mm x 45mm. Load capacity 180kg. REACH compliant, RoHs Compliant, USDA approved FDA approved.

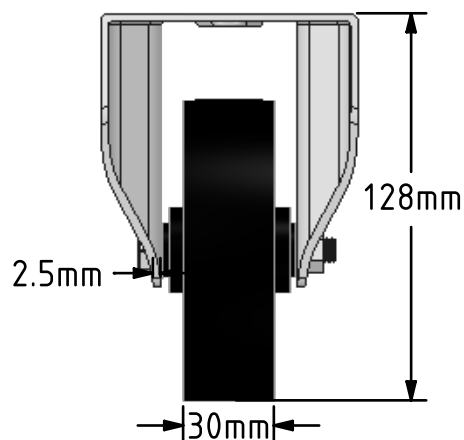
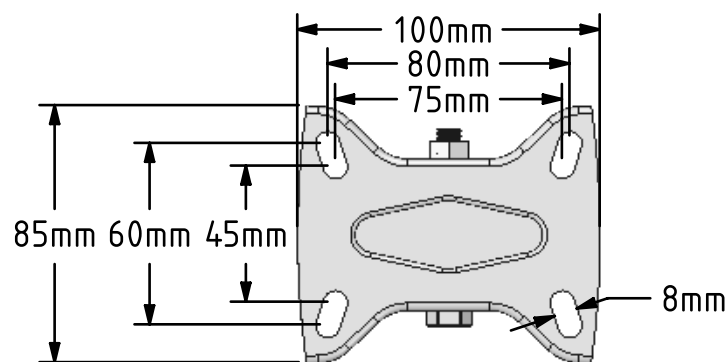

	NAME	DATE
DRAWN	Matt	22/03/18
APPROVED BY	Tim W	22/03/18
SCALE	2.5	22/03/18
WEIGHT	0.575kg	22/03/18

 BIL Group Ltd, Porte Marsh Road, Calne
 Wiltshire, SN11 9BW, United Kingdom
 Tel +44 (0)1249 822 222 Fax: +44 (0)1249 822 300
 www.bilgroup.co.uk

TITLE		BZXMF100TPTF	
SIZE	DWG NO.	REV	
A4	BILCW03BZXMF100TP3TF_01	1	
FILE NAME		SHEET 1 OF 1	
BILCW03BZXMF100TP3TF_01.PDF			

UNLESS OTHERWISE SPECIFIED DIMENSIONS ARE IN MILLIMETRES
 Unspecified Tolerances
 Machining ± 0.25mm
 Fabrication ± 1mm