

DRAWING DISCLAIMER  
 COPYRIGHT OF THIS DRAWING IS RESERVED BY BIL GROUP LTD. IT IS ISSUED ON CONDITION THAT IT IS NOT REPRODUCED, COPIED, OR DISCLOSED TO A THIRD PARTY EITHER WHOLLY OR IN PART WITHOUT THE CONSENT IN WRITING OF BIL GROUP LTD.

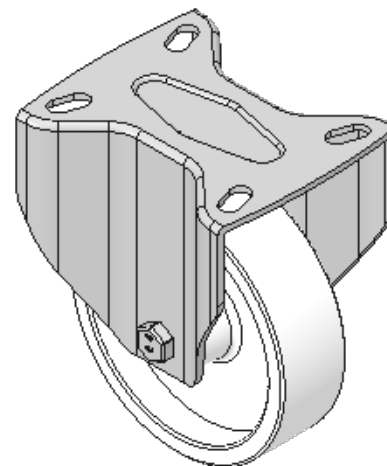

Description:  
 BZXMF100NYHT

Pressed steel fixed castor with a top plate fixing fitted with a off white nylon wheel with a plain bearing . Wheel diameter 100mm, tread width 30mm, overall height 128mm, top plate 100mm x 85mm, hole centres 80mm x 60mm or 75mm x 45mm. Load capacity 180kg at a maximum 150c.

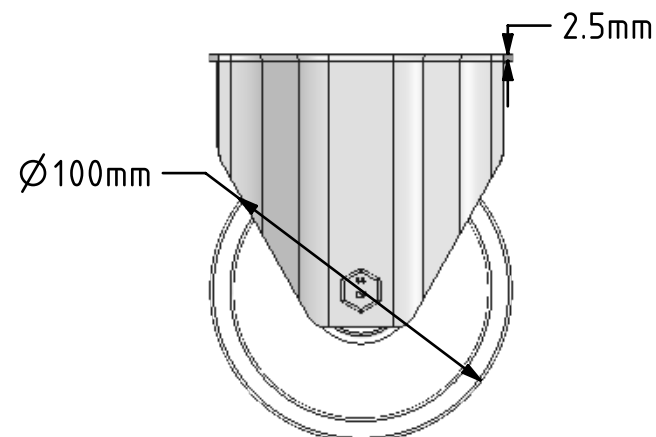
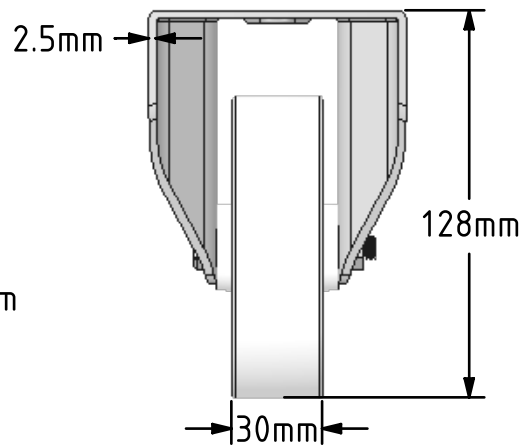
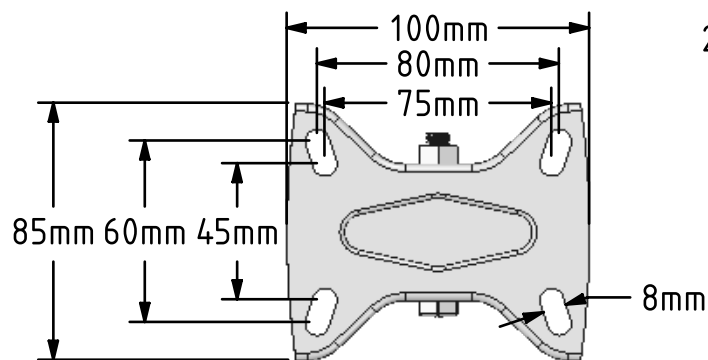
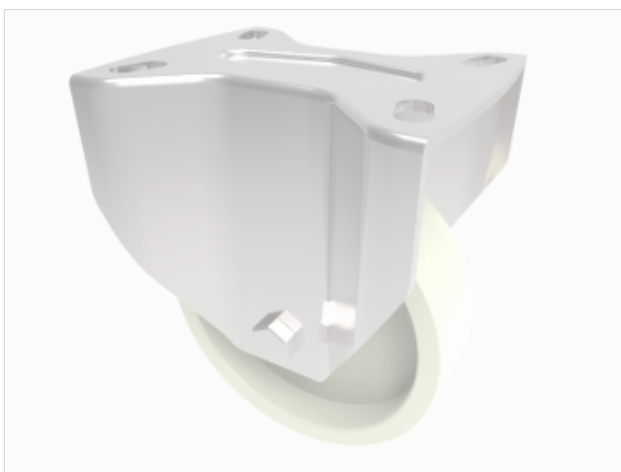

	NAME	DATE
DRAWN	Matt	23/03/18
APPROVED BY	Kevin	23/03/18
SCALE	2:5	23/03/18
WEIGHT	0.573kg	23/03/18

UNLESS OTHERWISE SPECIFIED DIMENSIONS ARE IN MILLIMETRES

Unspecified Tolerances  
 Machining ± 0.25mm  
 Fabrication ± 1mm



BIL Group Ltd, Porte Marsh Road, Calne  
 Wiltshire, SN11 9BW, United Kingdom  
 Tel +44 (0)1249 822 222 Fax: +44 (0)1249 822 300  
 www.bilgroup.co.uk

TITLE

BZXMF100NYHT

SIZE DWG NO.

A4

BILCW03BZXMF100NYHT\_\_01

REV

1

FILE NAME BILCW03BZXMF100NYHT\_\_01.PDF

SHEET 1 OF 1