

**DRAWING DISCLAIMER**  
 COPYRIGHT OF THIS DRAWING IS RESERVED BY BIL GROUP LTD. IT IS ISSUED ON CONDITION THAT IT IS NOT REPRODUCED, COPIED, OR DISCLOSED TO A THIRD PARTY EITHER WHOLLY OR IN PART WITHOUT THE CONSENT IN WRITING OF BIL GROUP LTD.

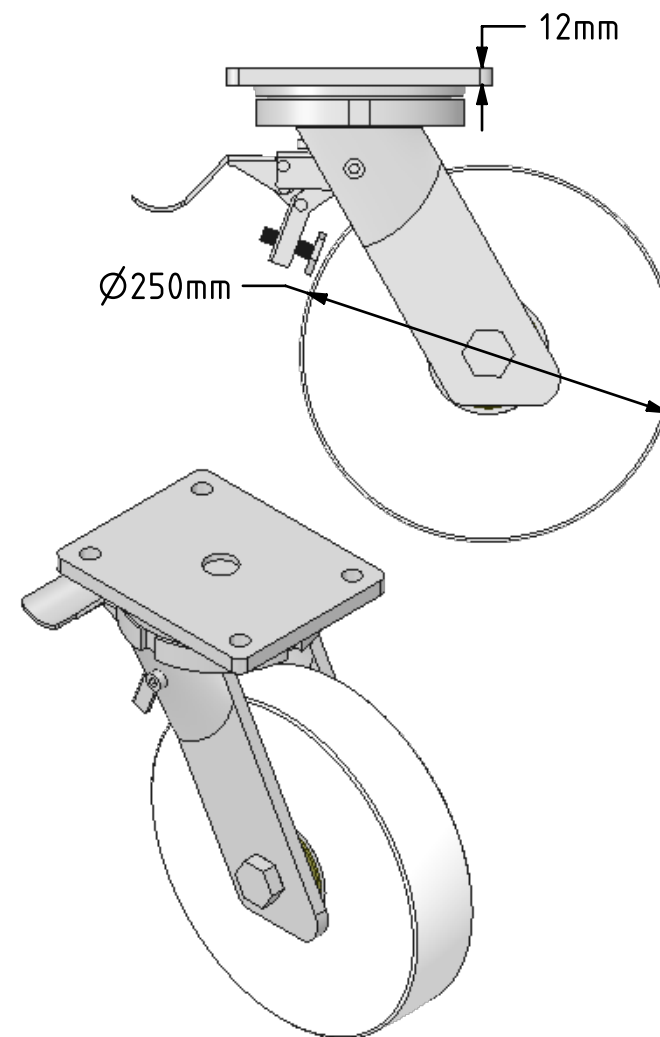

**Description:**  
 BZQ250NYBJSWB

Fabricated swivel castor with a flat plate fixing fitted with a heavy duty white nylon wheel with ball bearings and a total lock brake. Wheel diameter 250mm, tread width 55mm, overall height 314mm, plate size 175mm x 140mm, hole centres 140mm x 105mm. Load capacity 3000kg.

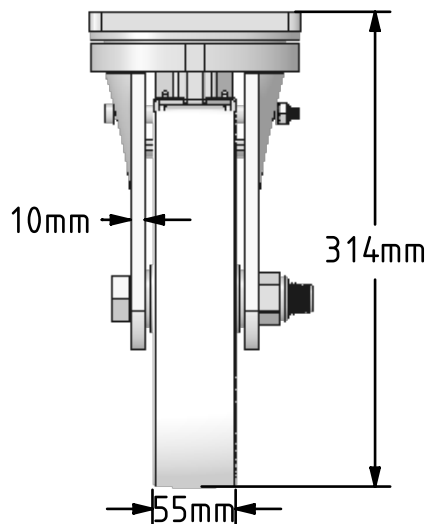
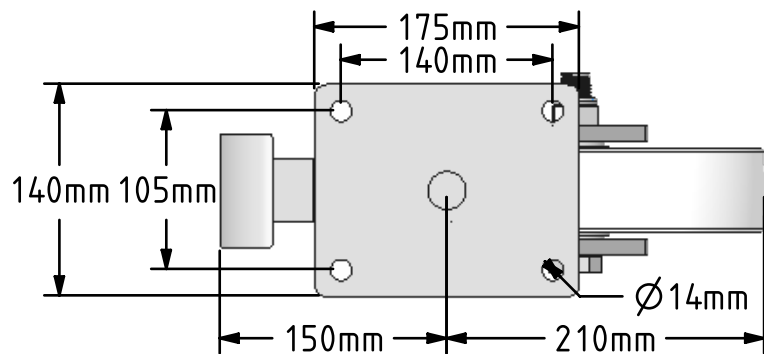

	NAME	DATE
DRAWN	Matt	31/05/18
APPROVED BY	Tim W	31/05/18
SCALE	1:5	31/05/18
WEIGHT	11.945kg	31/05/18

UNLESS OTHERWISE SPECIFIED DIMENSIONS ARE IN MILLIMETRES

Unspecified Tolerances  
 Machining ± 0.25mm  
 Fabrication ± 1mm



BIL Group Ltd, Porte Marsh Road, Calne  
 Wiltshire, SN11 9BW, United Kingdom  
 Tel +44 (0)1249 822 222 Fax: +44 (0)1249 822 300  
 www.bilgroup.co.uk

TITLE

**BZQ250NYBJSWB**

SIZE DWG NO.

A4

BILCW03BZQ250NYBJSWB\_02

REV

2

FILE NAME BILCW03BZQ250NYBJSWB\_02.PDF

SHEET 1 OF 1