

**DRAWING DISCLAIMER**  
 COPYRIGHT OF THIS DRAWING IS RESERVED BY BIL GROUP LTD. IT IS ISSUED ON CONDITION THAT IT IS NOT REPRODUCED, COPIED, OR DISCLOSED TO A THIRD PARTY EITHER WHOLLY OR IN PART WITHOUT THE CONSENT IN WRITING OF BIL GROUP LTD.

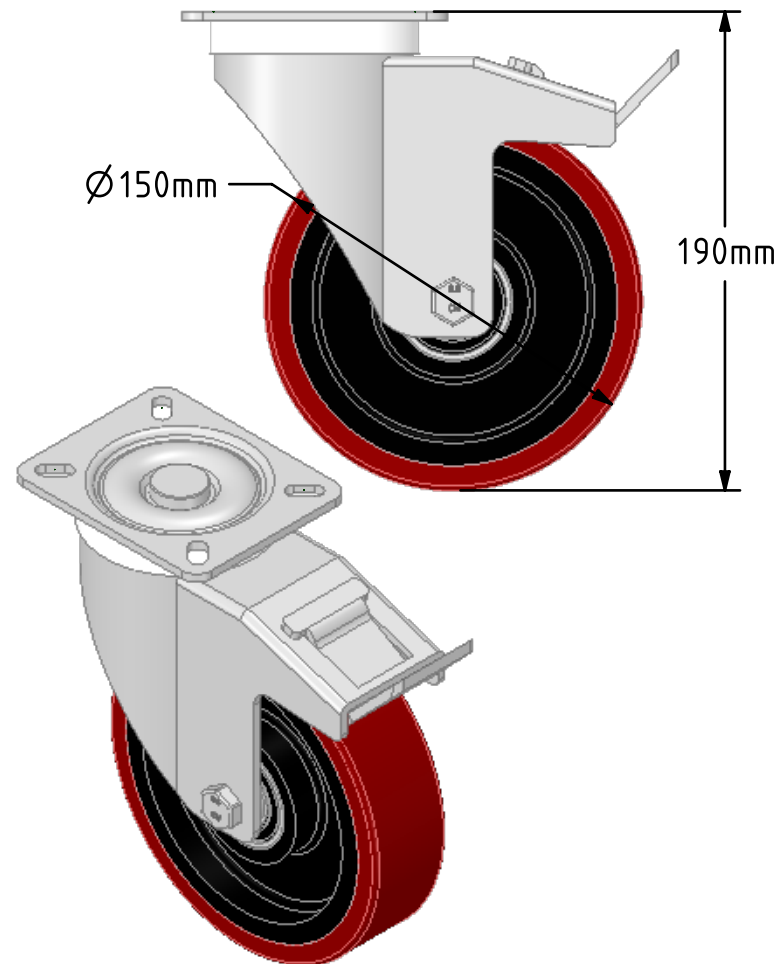

**Description:**  
 BZPHL150PTBJSWB

Pressed steel swivel castor with a top plate fixing fitted with brown polyurethane tyre cast iron centred wheel with ball bearings and a total lock brake. Wheel diameter 150mm, tread width 40mm, overall height 190mm, top plate 105mm x 86mm, hole centres 80mm x 60mm. Load capacity 400Kg.

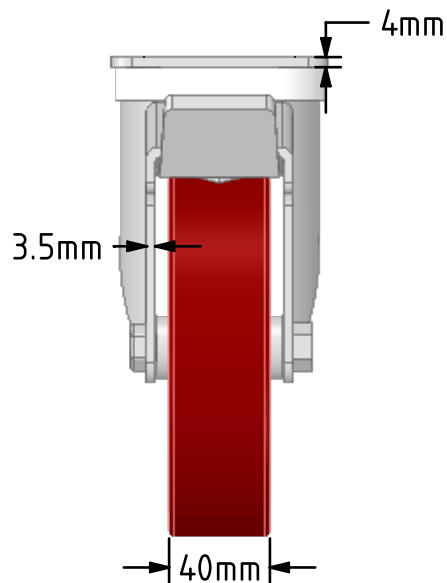
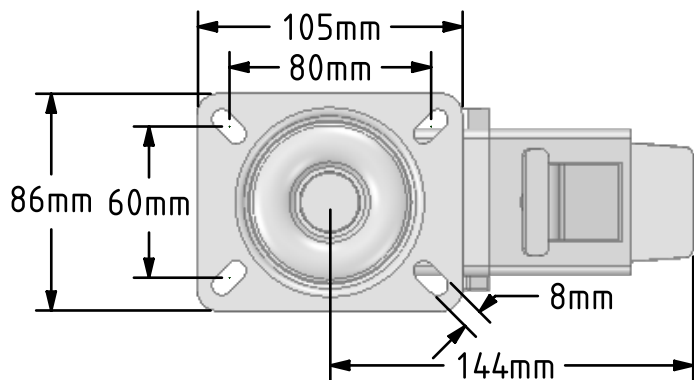

	NAME	DATE
DRAWN	Matt	22/10/18
APPROVED BY	Chris	22/10/18
SCALE	1:3	22/10/18
WEIGHT	3.726kg	22/10/18



BIL Group Ltd, Porte Marsh Road, Calne  
 Wiltshire, SN11 9BW, United Kingdom  
 Tel +44 (0)1249 822 222 Fax: +44 (0)1249 822 300  
 www.bilgroup.co.uk

TITLE		REV
BZPHL150PTBJSWB		2
SIZE	DWG NO.	
A4	BILCW03BZPHL150PTBJSWB_02	

UNLESS OTHERWISE SPECIFIED DIMENSIONS ARE IN MILLIMETRES  
 Unspecified Tolerances  
 Machining ± 0.25mm  
 Fabrication ± 1mm

FILE NAME BILCW03BZPHL150PTBJSWB\_02.PDF SHEET 1 OF 1