

DRAWING DISCLAIMER
 COPYRIGHT OF THIS DRAWING IS RESERVED BY BIL GROUP LTD. IT IS ISSUED ON CONDITION THAT IT IS NOT REPRODUCED, COPIED, OR DISCLOSED TO A THIRD PARTY EITHER WHOLLY OR IN PART WITHOUT THE CONSENT IN WRITING OF BIL GROUP LTD.

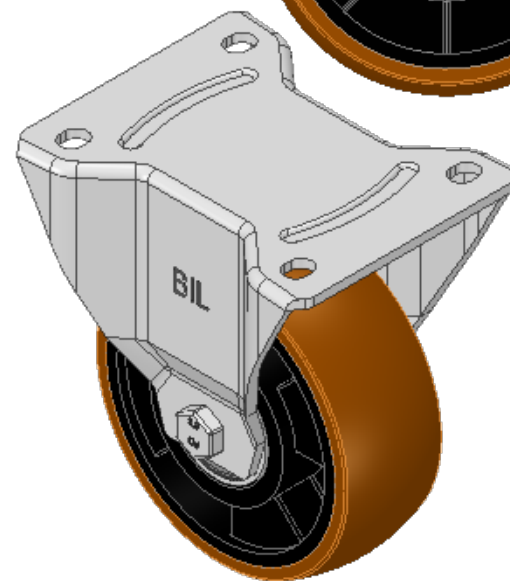

Description:
 BZPHF125XPBJ

Pressed steel fixed castor with a top plate fixing fitted with a brown polyurethane on black nylon centred wheel with ball bearings. Wheel diameter 125mm, tread width 45mm, overall height 158mm, top plate 135mm x 110mm, hole centres 105mm x 80mm. Load capacity 400kg.

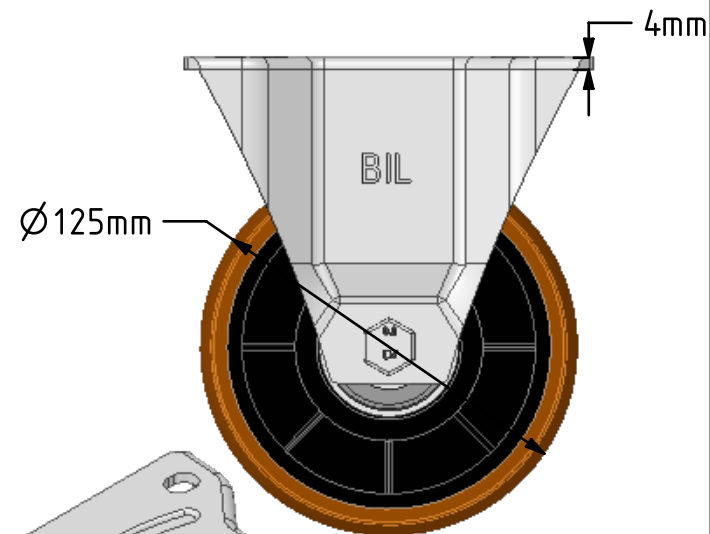
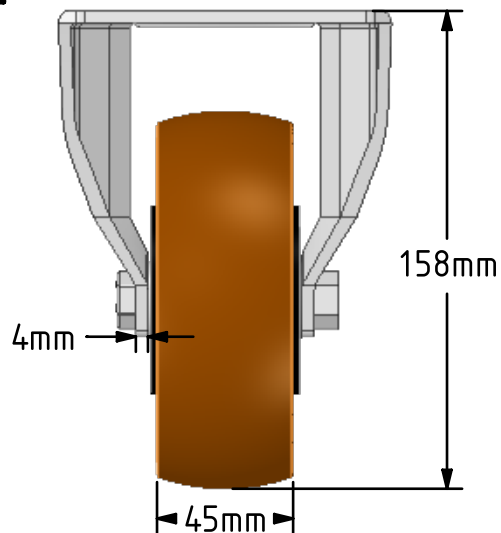
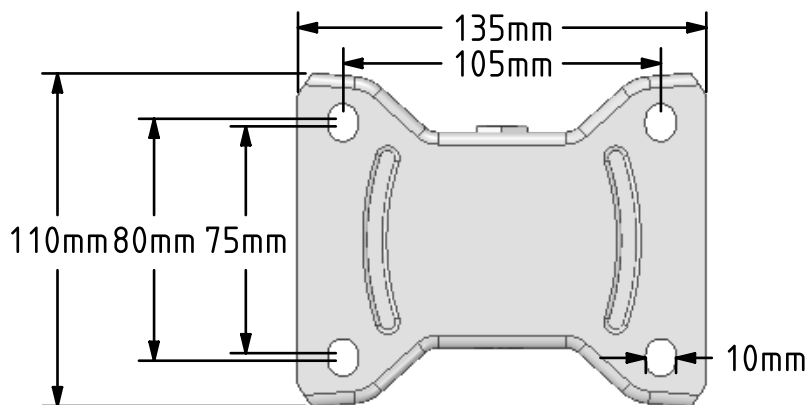

	NAME	DATE
DRAWN	Matt	04/12/18
APPROVED BY	Tim W	04/12/18
SCALE	2:5	04/12/18
WEIGHT	1.366kg	04/12/18

UNLESS OTHERWISE SPECIFIED DIMENSIONS ARE IN MILLIMETRES

Unspecified Tolerances
 Machining ± 0.25mm
 Fabrication ± 1mm



BIL Group Ltd, Porte Marsh Road, Calne
 Wiltshire, SN11 9BW, United Kingdom
 Tel +44 (0)1249 822 222 Fax: +44 (0)1249 822 300
 www.bilgroup.co.uk

TITLE

BZPHF125XPBJ

SIZE DWG NO.
 A4 BILCW03BZPHF125XPBJ_01

REV
 1

FILE NAME BILCW03BZPHF125XPBJ_01.PDF SHEET 1 OF 1