

DRAWING DISCLAIMER
 COPYRIGHT OF THIS DRAWING IS RESERVED BY BIL GROUP LTD. IT IS ISSUED ON CONDITION THAT IT IS NOT REPRODUCED, COPIED, OR DISCLOSED TO A THIRD PARTY EITHER WHOLLY OR IN PART WITHOUT THE CONSENT IN WRITING OF BIL GROUP LTD.

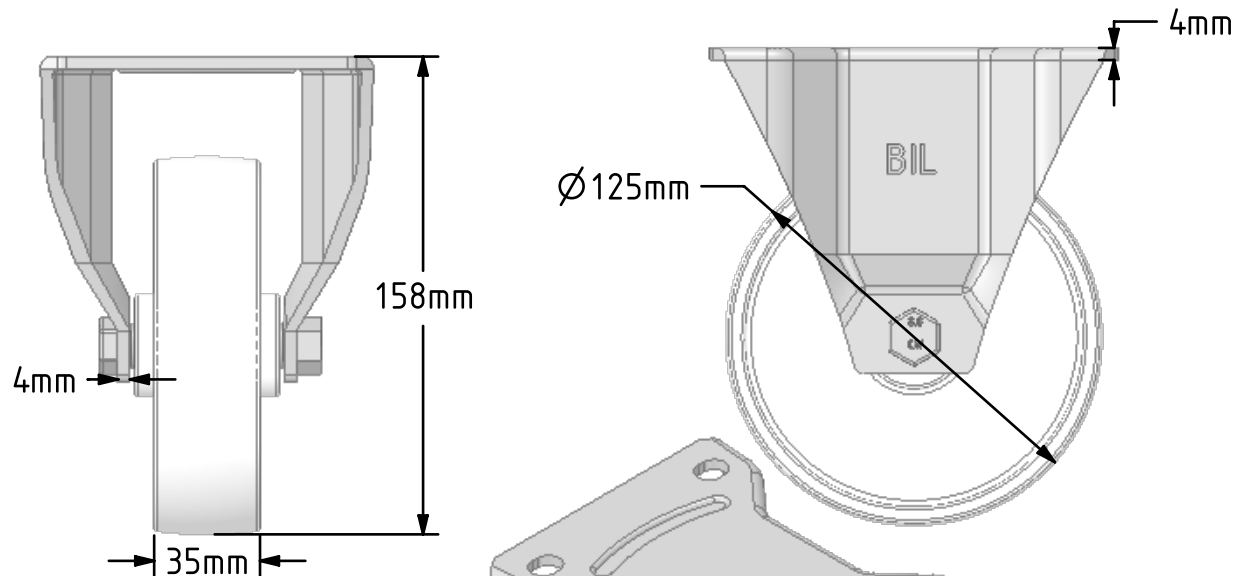

Description:
 BZPHF125NYB

Pressed steel fixed castor with a flat plate fixing fitted with a white nylon wheel with a roller bearing. Wheel diameter 125mm, tread width 35mm, overall height 158mm, plate size 135mm x 115mm, hole centres 105mm x 80mm/75mm. Load capacity 300kg.

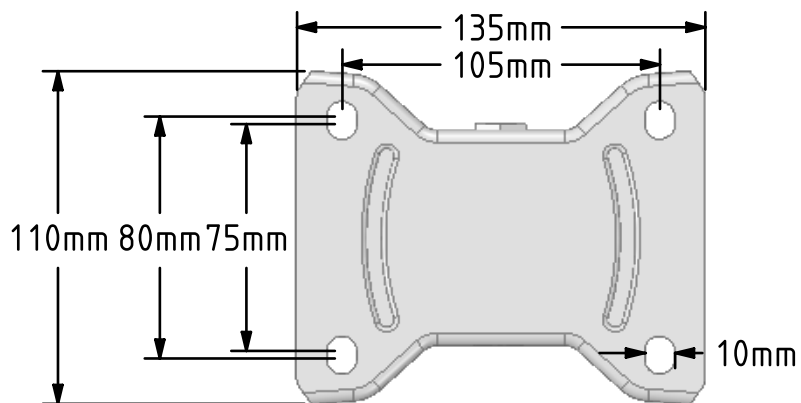

	NAME	DATE
DRAWN	Matt	01/11/18
APPROVED BY	Chris	01/11/18
SCALE	2:5	01/11/18
WEIGHT	0.934kg	01/11/18

UNLESS OTHERWISE SPECIFIED DIMENSIONS ARE IN MILLIMETRES

Unspecified Tolerances
 Machining ± 0.25mm
 Fabrication ± 1mm

 BIL Group Ltd, Porte Marsh Road, Calne Wiltshire, SN11 9BW, United Kingdom
 Tel +44 (0)1249 822 222 Fax: +44 (0)1249 822 300
 www.bilgroup.co.uk

TITLE		
BZPHF125NYB		
SIZE	DWG NO.	REV
A4	BILCW03BZPHF125NYB__01	1
FILE NAME	BILCW03BZPHF125NYB__01.PDF SHEET 1 OF 1	