

DRAWING DISCLAIMER  
 COPYRIGHT OF THIS DRAWING IS RESERVED BY BIL GROUP LTD. IT IS ISSUED ON CONDITION THAT IT IS NOT REPRODUCED, COPIED, OR DISCLOSED TO A THIRD PARTY EITHER WHOLLY OR IN PART WITHOUT THE CONSENT IN WRITING OF BIL GROUP LTD.

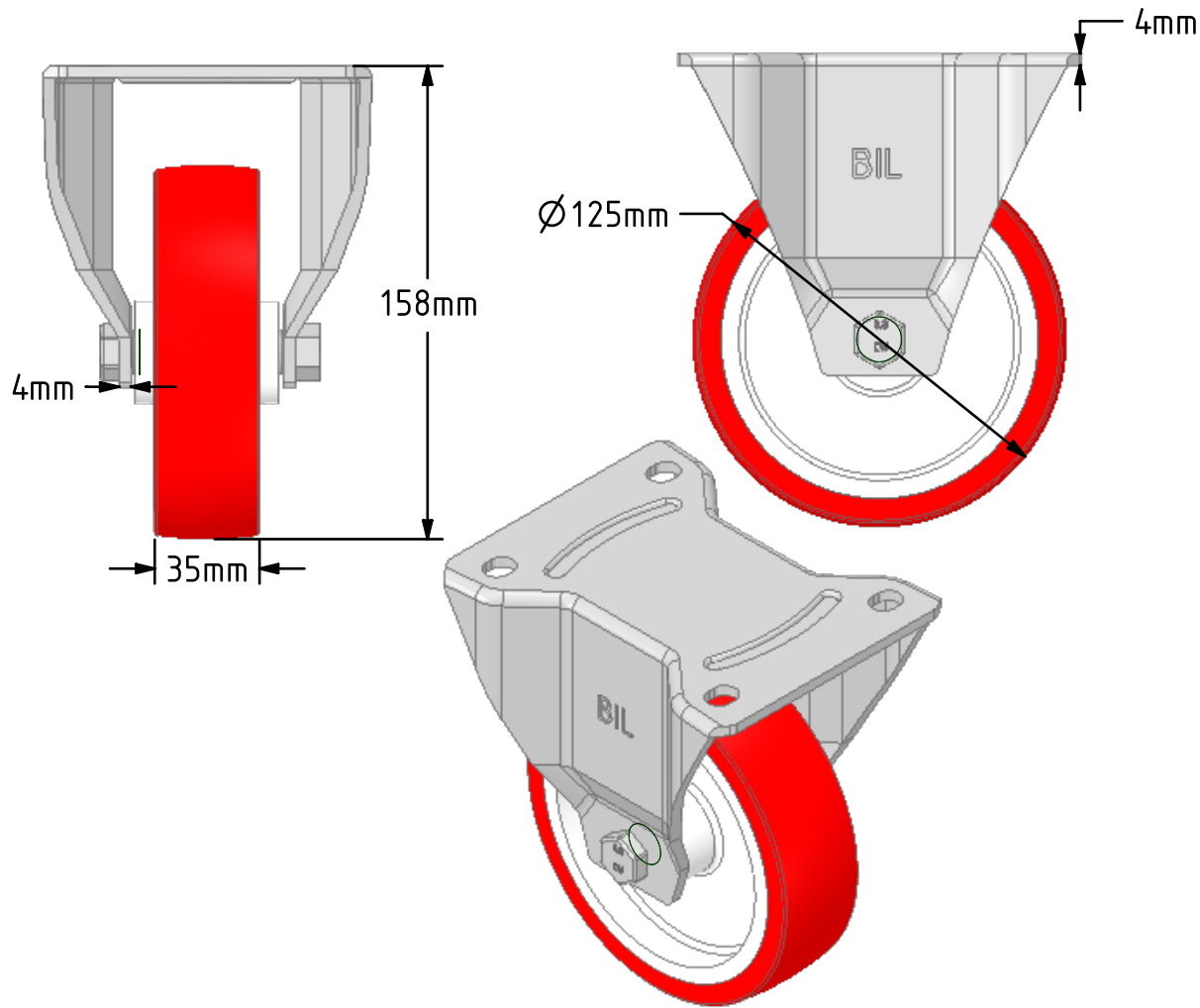

Description:  
 BZPHF125NPB

Pressed steel fixed castor with a top plate fixing fitted with a red polyurethane on white nylon centred wheel with a roller bearing. Wheel diameter 125mm, tread width 35mm, overall height 158mm, top plate 135mm x 110mm, hole centres 105mm x 80/75mm. Load capacity 300kg.

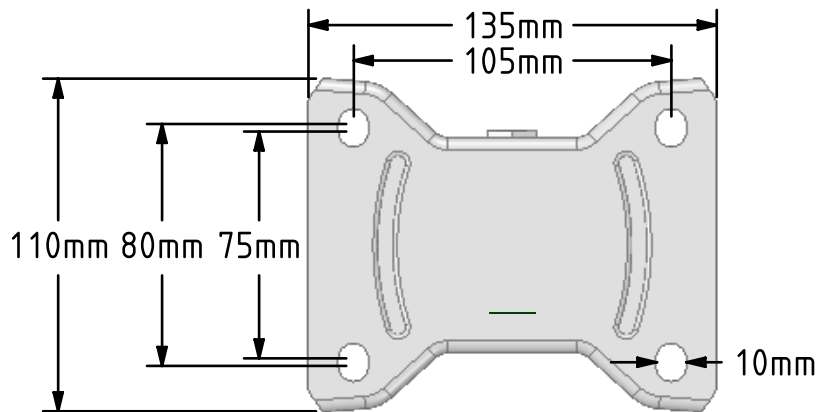

	NAME	DATE
DRAWN	Matt	27/11/18
APPROVED BY	Chris	27/11/18
SCALE	2:5	27/11/18
WEIGHT	1.037kg	27/11/18

UNLESS OTHERWISE SPECIFIED DIMENSIONS ARE IN MILLIMETRES  
 Unspecified Tolerances  
 Machining ± 0.25mm  
 Fabrication ± 1mm

 BIL Group Ltd, Porte Marsh Road, Calne Wiltshire, SN11 9BW, United Kingdom Tel +44 (0)1249 822 222 Fax: +44 (0)1249 822 300 www.bilgroup.co.uk		TITLE	
		BZPHF125NPB	
SIZE	DWG NO.	REV	
A4	BILCW03BZPHF125NPB_01	1	
FILE NAME	BILCW03BZPHF125NPB_01.PDF		SHEET 1 OF 1