

DRAWING DISCLAIMER  
 COPYRIGHT OF THIS DRAWING IS RESERVED BY BIL GROUP LTD. IT IS ISSUED ON CONDITION THAT IT IS NOT REPRODUCED, COPIED, OR DISCLOSED TO A THIRD PARTY EITHER WHOLLY OR IN PART WITHOUT THE CONSENT IN WRITING OF BIL GROUP LTD.

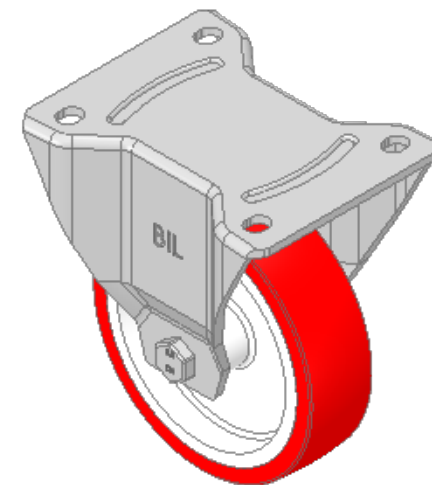

Description:  
 BZPHF125NP

Pressed steel fixed castor fitted with a red polyurethane tyre on a white nylon centred wheel, 100mm overall wheel diameter, 35mm tread width, 158mm overall height, 135x110mm top plate with hole centres of 105x80/75mm and a load capacity of 300kg.

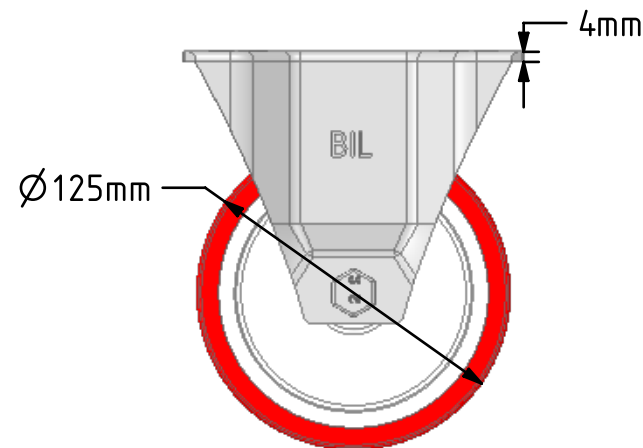
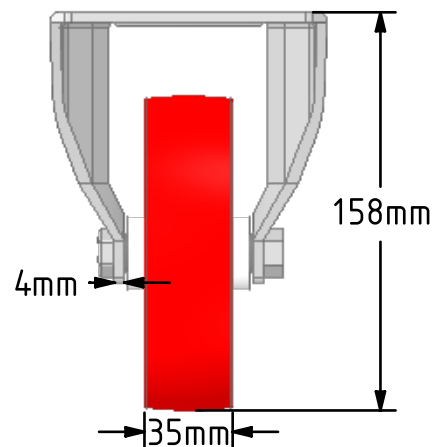
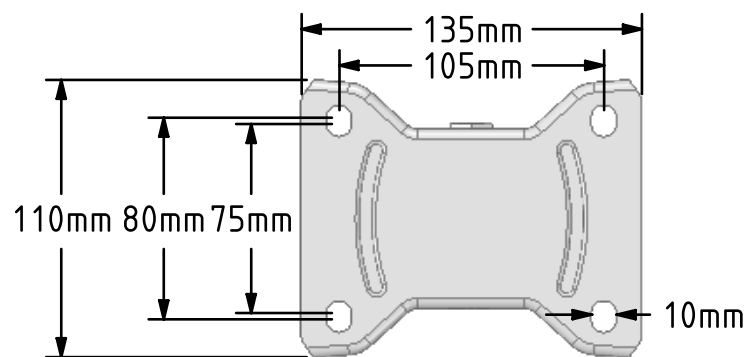
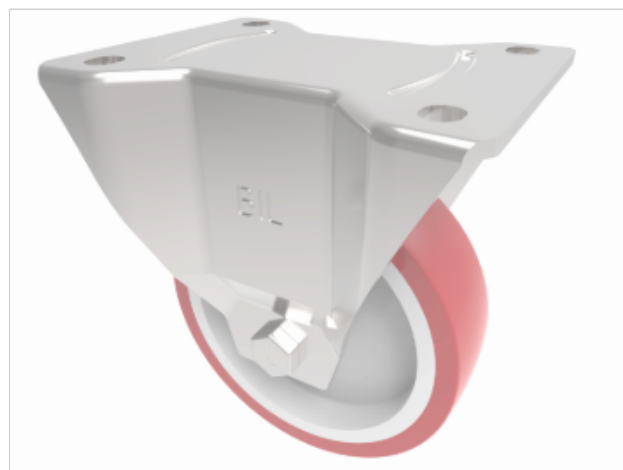

|             | NAME    | DATE     |
|-------------|---------|----------|
| DRAWN       | Matt    | 27/11/18 |
| APPROVED BY | Chris   | 27/11/18 |
| SCALE       | 1:3     | 27/11/18 |
| WEIGHT      | 1.004kg | 27/11/18 |

UNLESS OTHERWISE SPECIFIED DIMENSIONS ARE IN MILLIMETRES

Unspecified Tolerances  
 Machining ± 0.25mm  
 Fabrication ± 1mm



BIL Group Ltd, Porte Marsh Road, Calne  
 Wiltshire, SN11 9BW, United Kingdom  
 Tel +44 (0)1249 822 222 Fax: +44 (0)1249 822 300  
 www.bilgroup.co.uk

TITLE

BZPHF125NP

| SIZE | DWG NO.              | REV |
|------|----------------------|-----|
| A4   | BILCW03BZPHF125NP_01 | 1   |

FILE NAME BILCW03BZPHF125NP\_01.PDF SHEET 1 OF 1