

DRAWING DISCLAIMER
 COPYRIGHT OF THIS DRAWING IS RESERVED BY BIL GROUP LTD. IT IS ISSUED ON CONDITION THAT IT IS NOT REPRODUCED, COPIED, OR DISCLOSED TO A THIRD PARTY EITHER WHOLLY OR IN PART WITHOUT THE CONSENT IN WRITING OF BIL GROUP LTD.

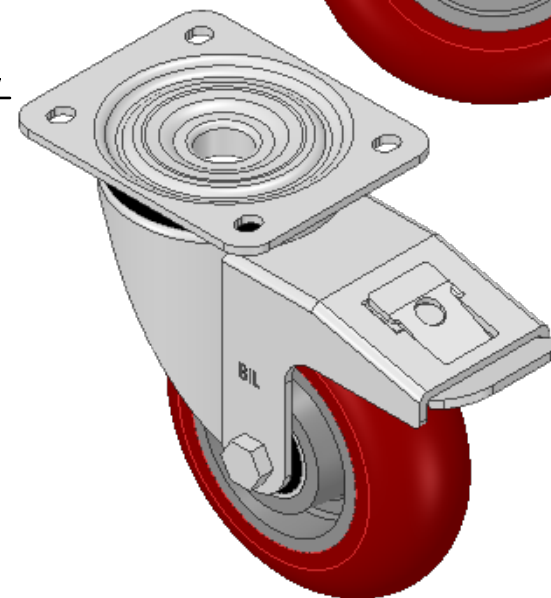

Description:
 BZPH150RPTABJSWB

Pressed steel swivel castor with a top plate fixing fitted with a round profile ergonomic polyurethane on aluminium centred wheel with ball bearings and total lock brake, Wheel diameter 150mm, tread width 50mm, overall height 190mm, top plate 135mm x 110mm, hole centres 105mm x 80/75mm. Load capacity 500kg.

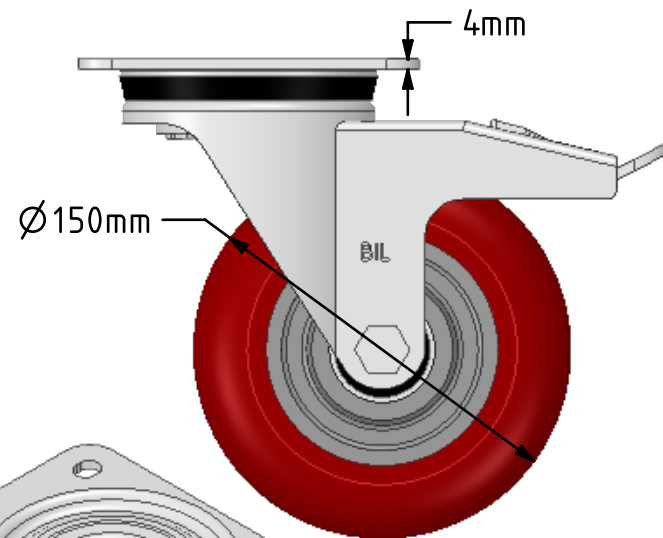
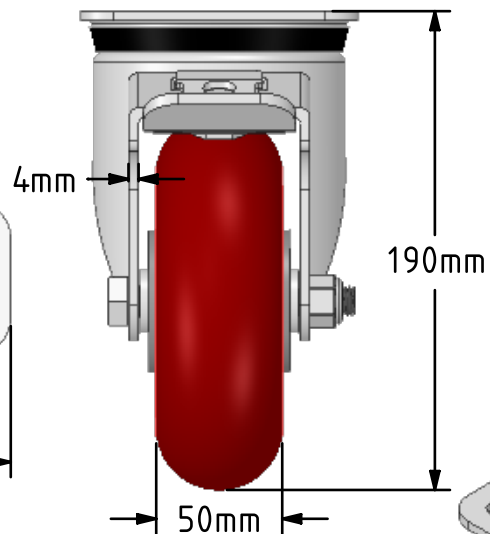
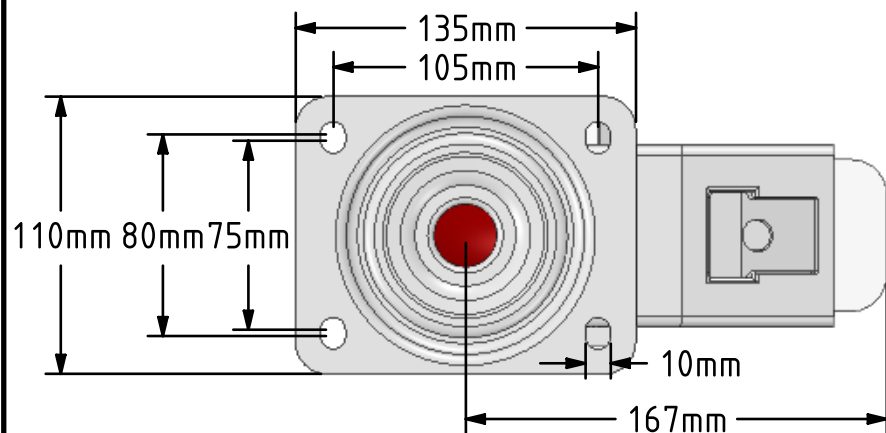

	NAME	DATE
DRAWN	Matt	03/04/19
APPROVED BY	Chris	03/04/19
SCALE	1:3	03/04/19
WEIGHT	3.31kg	03/04/19

UNLESS OTHERWISE SPECIFIED DIMENSIONS ARE IN MILLIMETRES

Unspecified Tolerances
 Machining ± 0.25mm
 Fabrication ± 1mm



BIL Group Ltd, Porte Marsh Road, Calne
 Wiltshire, SN11 9BW, United Kingdom
 Tel +44 (0)1249 822 222 Fax: +44 (0)1249 822 300
 www.bilgroup.co.uk

TITLE

BZPH150RPTABJSWB

SIZE	DWG NO.	REV
A4	BILCW03BZPH150RPTABJSWB__01	1

FILE NAME BILCW03BZPH150RPTABJSWB__01.PDF SHEET 1 OF 1