

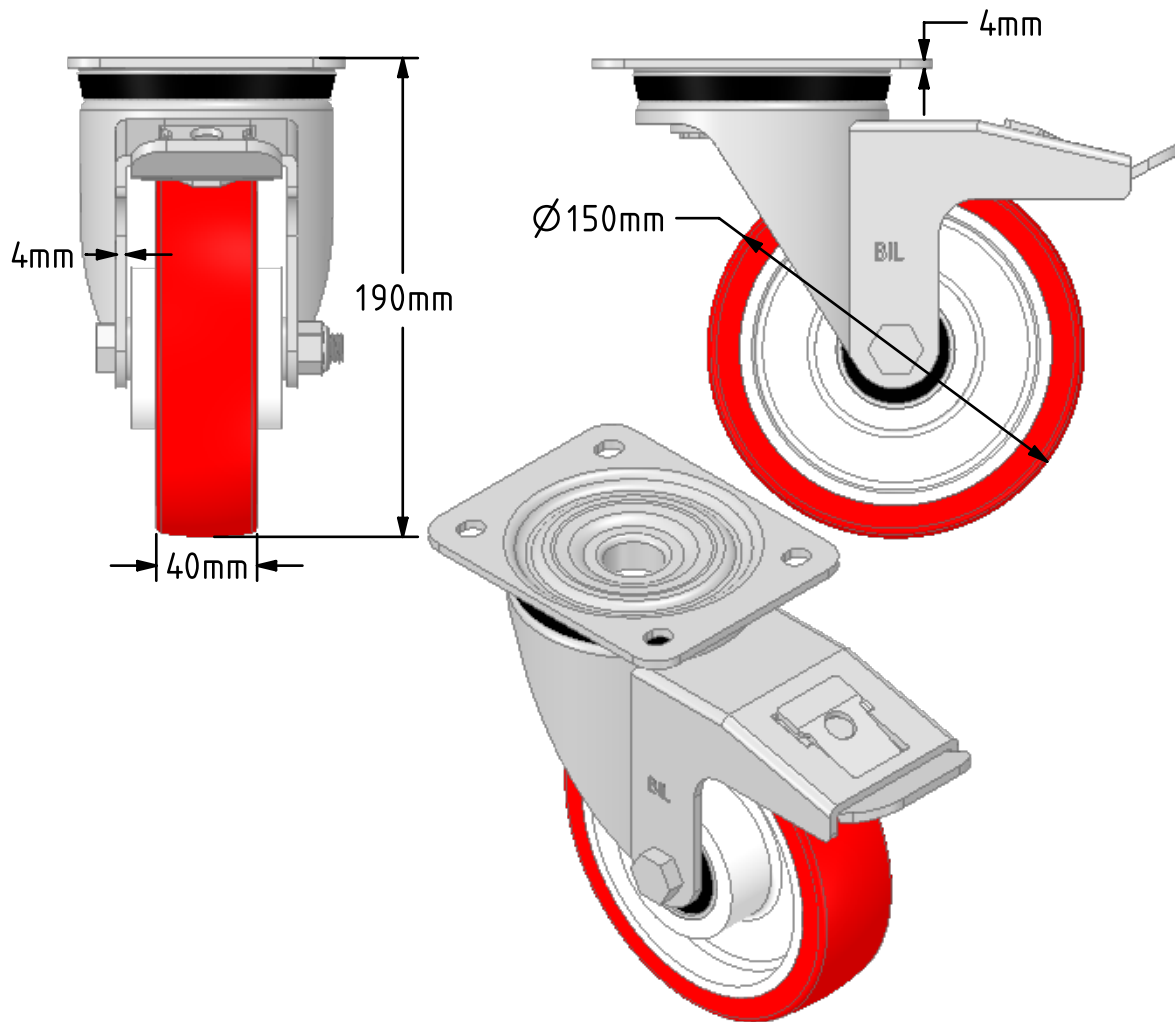

DRAWING DISCLAIMER
 COPYRIGHT OF THIS DRAWING IS RESERVED BY BIL GROUP LTD. IT IS ISSUED ON CONDITION THAT IT IS NOT REPRODUCED, COPIED, OR DISCLOSED TO A THIRD PARTY EITHER WHOLLY OR IN PART WITHOUT THE CONSENT IN WRITING OF BIL GROUP LTD.

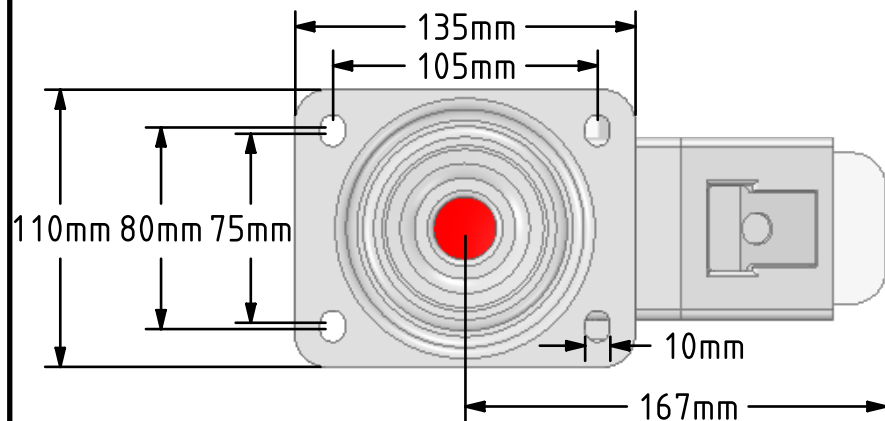

Description:
 BZPH150NPBJSWB

Pressed steel swivel castor with a top plate fixing fitted with a red polyurethane tyre on white nylon centred wheel with ball bearings and total lock brake. Wheel diameter 150mm, tread width 40mm, overall height 190mm, plate size 135mm x 110mm, hole centres 105mm x 80/75mm. Load capacity 500kg.



	NAME	DATE	BIL Group Ltd, Porte Marsh Road, Calne Wiltshire, SN11 9BW, United Kingdom Tel +44 (0)1249 822 222 Fax: +44 (0)1249 822 300 www.bilgroup.co.uk	
DRAWN	Matt	27/11/18		
APPROVED BY	Chris	27/11/18		
SCALE	1:3	27/11/18		
WEIGHT	2.632kg	27/11/18		
UNLESS OTHERWISE SPECIFIED DIMENSIONS ARE IN MILLIMETRES			SIZE	DWG NO.
Unspecified Tolerances Machining ± 0.25mm Fabrication ± 1mm			A4	BILCW03BZPH150NPBJSWB_01
			TITLE	REV
			BZPH150NPBJSWB	
			FILE NAME	SHEET 1 OF 1
			BILCW03BZPH150NPBJSWB_01.PDF	1