

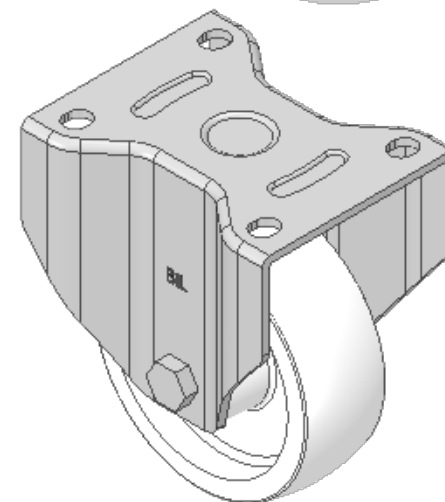

DRAWING DISCLAIMER
 COPYRIGHT OF THIS DRAWING IS RESERVED BY BIL GROUP LTD. IT IS ISSUED ON CONDITION THAT IT IS NOT REPRODUCED, COPIED, OR DISCLOSED TO A THIRD PARTY EITHER WHOLLY OR IN PART WITHOUT THE CONSENT IN WRITING OF BIL GROUP LTD.

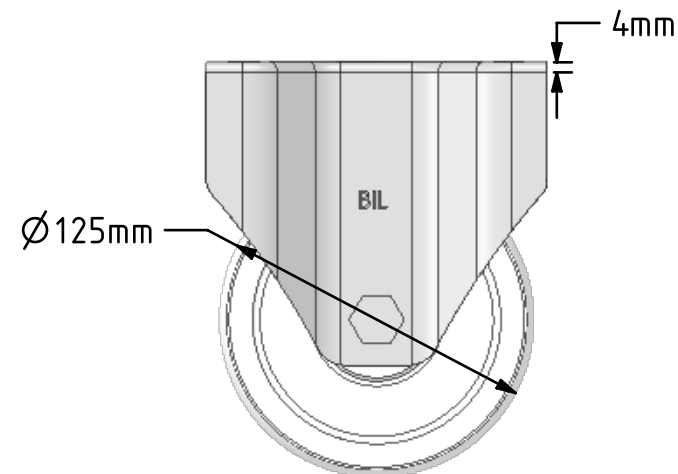
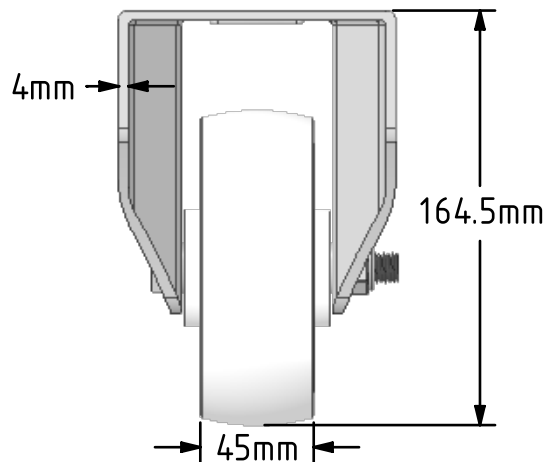
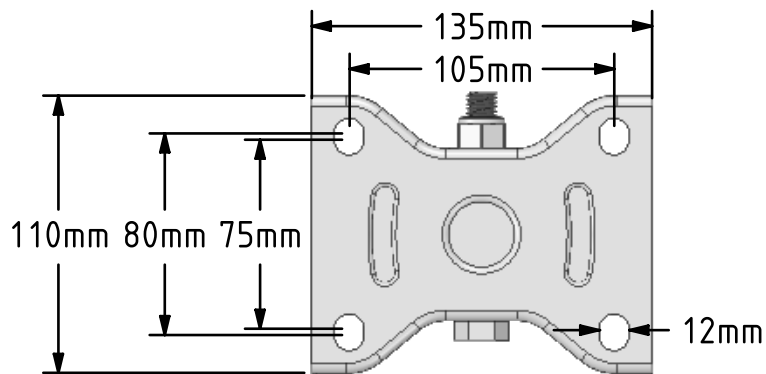
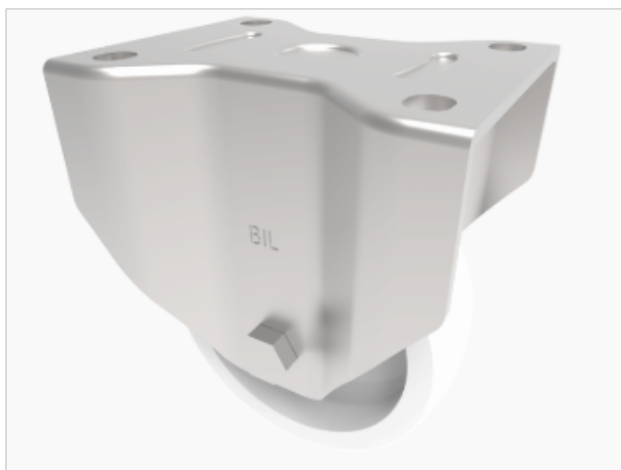

Description:
 BZPF125NYB

Pressed steel fixed castor with a top plate fixing fitted with a white nylon wheel with a roller bearing. Wheel diameter 125mm, tread width 45mm, overall height 164mm, plate size 135x110mm, hole centres 105mm x 80mm. Load capacity 750kg.



	NAME	DATE	BIL Group Ltd, Porte Marsh Road, Calne Wiltshire, SN11 9BW, United Kingdom Tel +44 (0)1249 822 222 Fax: +44 (0)1249 822 300 www.bilgroup.co.uk	
DRAWN	Matt	07/01/19	 TITLE BZPF125NYB	
APPROVED BY	Chris	07/01/19		
SCALE	1:3	07/01/19		
WEIGHT	1.585kg	07/01/19		
UNLESS OTHERWISE SPECIFIED DIMENSIONS ARE IN MILLIMETRES			SIZE	DWG NO.
Unspecified Tolerances Machining ± 0.25mm Fabrication ± 1mm			A4	BILCW03BZPF125NYB_01
			FILE NAME	BILCW03BZPF125NYB_01.PDF
				REV 1
				SHEET 1 OF 1